

Finishing Veneer Plaster Systems

6



Advances of Veneer Plaster

Veneer plaster has been growing in popularity as a wall finishing system. The speed of application for one-coat systems make it cost competitive with drywall, and the added smoothness of two-coat veneer provides a look of luxury and adds ease to decorating. With either system, the toughness of veneer plaster makes walls more durable and resistant to scuffs, gouges and impact damage.

Note that various organizations provide information about recommended standards or tolerances for finishing of veneer plaster systems. See pages 435 and 442 in the Appendix for information about standards and tolerances.

For instructions on the safe use of veneer plaster and related products, see Chapter 13, Safety Considerations, Material Handling.

Veneer Plaster Finishes

Veneer plaster finishes can be used in one or two-coat applications and can be given smooth or textured surfaces. Each method has its particular advantage. There is only one gypsum panel designed for use with DIAMOND and IMPERIAL veneer plasters: GRAND PRIX Plasterbase.

GRAND PRIX Plasterbase has a gypsum core faced with specially treated, multi-layered paper (blue) designed to provide a maximum bond to veneer plaster finishes. The paper's absorbent outer layers quickly and uniformly draw moisture from the veneer plaster finish for proper application and finishing; the moisture-resistant inner layers keep the core dry and rigid to resist sagging. Note: Gypsum base that has faded from the original light blue colour due to exposure to sunlight should be treated with either a plaster bonding agent or spray-applied alum solution before DIAMOND Interior Finish Plaster is applied.

Plaster Drying Conditions

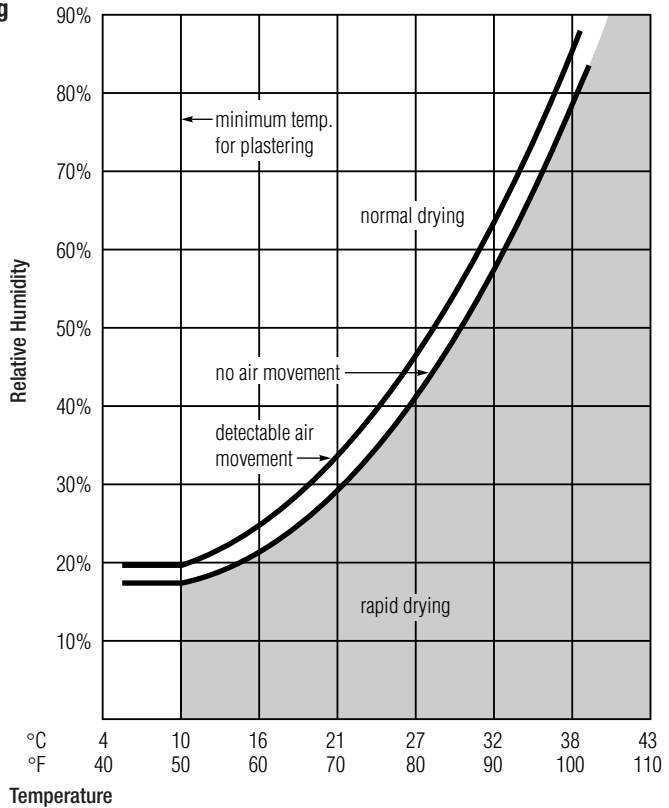

6

Two-Coat Veneer Finish Compared to many other finishes, two-coat veneer provides a more durable, abrasion-resistant surface and can be finished to a truer plane than one-coat applications. These finishes can be used with steel or wood framing wherever the ultimate in appearance is desired. Ready for next-day decorating, provided complete dryness has been reached. Assemblies with these monolithic gypsum surfaces offer excellent fire and sound ratings.

One-Coat Veneer Finish Provides a hard monolithic surface at low cost. Complete application—from bare studs to decorated walls and ceilings—takes no more than 48 to 72 hr., provided complete dryness has been reached. Assemblies with one-coat veneer plaster application meet fire and sound requirements, and shorten construction schedules for added profit.

Job Environment

Maintain building temperature in comfortable working range, above 13°C (55°F). Keep air circulation at minimum level prior to, during and following application until finish is dry.

If possible, maintain building temperature-humidity combination in the "normal drying" area of the graph. When dry conditions exist, relative humidity often can be increased by wetting down the floor periodically. During these periods, make every effort to reduce air movement by

closing windows and deflecting heater blower and duct output away from the surfaces being plastered. If building temperature-humidity combination is in the "rapid drying" area of the graph, special joint treatment measures must be taken. These include the use of DURABOND 45 or 90 Joint Compounds which are faster-setting and CGC Drywall Paper Tape.

Grounds

Correct thickness of veneer plaster finish is one of the most important factors in obtaining good results. To insure proper thickness, all corner beads, trim and expansion joints must be of the recommended type and be properly set.

Accessories must provide grounds for the following minimum plaster thicknesses:

1. Over veneer gypsum base, one coat... 1.6 mm (1/16 in.)
2. Over veneer gypsum base, two coats... 2.4 mm (3/32 in.)

Selection of Joint Treatment System

Under normal working conditions, joints of veneer plaster systems may be treated by applying IMPERIAL Brand Type P (pressure-sensitive) or Type S (staple) to the joints and then applying the veneer plaster basecoat or finish to preset the tape. However, there are a number of special situations that require the use of DURABOND Setting-Type Drywall Compound and CGC Drywall Paper Tape.

Note: Under the following conditions DURABOND Drywall Compound and CGC Drywall Paper Tape must be used:

1. where two-coat finish is applied over 12.7 mm (1/2") or 15.9 mm (5/8") base on 600 mm (24") o.c. framing;
2. where one-coat DIAMOND Interior Finish Plaster or IMPERIAL Finish is applied over 15.9 mm (5/8") base on 600 mm (24") o.c. framing;
3. where GRAND PRIX Gypsum Base and veneer plaster is used over steel framing.

Trim Accessory Application

Trim accessories simplify and enhance the finishing of veneer plaster assemblies. The accessories are low in cost, easily applied and designed to work together for long-lasting, trouble-free construction. All are suitable for steel-frame and wood-frame construction.

Corner Bead Application

SHEETROCK Brand Corner Reinforcements provide strong, durable protection for outside angle corners, uncased openings, pilasters, beams and soffits. The exposed nose of the bead resists impact and forms a screed for finishing. Corner bead should be installed in one piece unless length of corner exceeds stock bead lengths. Install as noted for each product following.

SHEETROCK Brand No. 800 and No. 900 Corner Beads are galvanized fine-mesh, expanded-flange corner beads especially designed for veneer plaster construction. Apply No. 800 or No. 900 Corner Bead with nails through the board into wood framing or to board alone in wood or steel-framed assemblies with 14 mm (9/16") galvanized staples spaced 300 mm (12") o.c. through both flanges. Fasteners

should be placed opposite one another in both flanges. Both beads provide superior reinforcement with veneer plaster finishes through approximately 300 keys per metre.

Use No. 800 for one-coat applications. It provides the proper 1.6 mm (1/16") ground height for one-coat finishing.

Use No. 900 for two-coat applications. It provides the 2.4 mm (3/32") ground height needed for two-coat applications.

On masonry corners, hold bead firmly against the corner and grout both flanges with IMPERIAL Brand Plaster Finish. On monolithic concrete apply a high-grade bonding agent, such as CGC Plaster Bonder, over the corner before placing the bead and grouting. Preset all beads with a veneer finish.

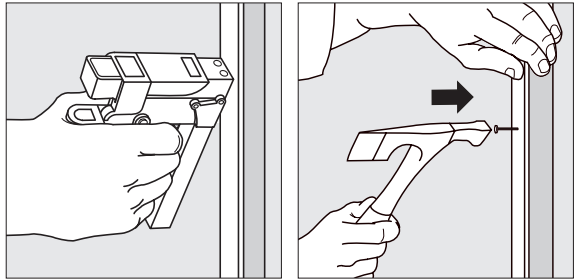

Stapling is the standard way to attach No. 800 Corner Bead. For wood studs, nails in both bead flanges are also satisfactory. Fasteners to be corrosion-resistant.

6

Metal Trim Application

SHEETROCK Brand Metal Trim serves to protect and finish gypsum base at window framing and door jambs; also used at ceiling-wall intersections and partition perimeters to form a recess for acoustical sealant. Also serves as a relief joint at the intersection of dissimilar constructions, such as gypsum board to concrete.

No. 800 & 900 Corner Bead.

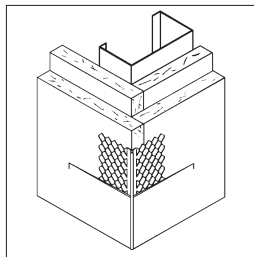

Metal trims provide maximum protection and neat finished edges to gypsum bases at window and door jambs, at internal angles and at intersections where panels abut other materials. They are easily installed by nailing or screwing through the proper leg of trim. Various configurations are available depending on the required application.

Control Joint Application

Proper installation of control joints in wall and ceiling membranes should include breaking the gypsum base behind the control joint. In ceiling construction, the framing should also be broken, and in partitions, separate studs should be used on each side of the control joints. Control joints should be positioned to intersect light fixtures, air diffusers, door openings and other areas of stress concentration.

Gypsum construction should be isolated with control joints where (a) partitions or ceilings of dissimilar construction meet and remain in the

same plane; (b) wings of “L”, “U” and “T” shaped ceiling areas are joined; and (c) expansion or control joints occur in the base wall construction and/or building structure. Just as important, control joints should be used in the face of gypsum partitions and ceilings when the size of the surface exceeds the following control-joint spacings; Partitions, 9 m (30 ft.) maximum in either direction; Interior Ceilings (with perimeter relief), 15 m (50 ft.) maximum in either direction; Interior Ceilings (without perimeter relief), 9 m (30 ft.) maximum in either direction; and Exterior Ceilings, 9 m (30 ft.) maximum in either direction.

Ceiling-height door frames may be used as vertical control joints for partitions; however, door frames of lesser height may only be used as control joints if standard control joints extend to the ceiling from both corners of the top of the door frame. When planning locations for control joints in the ceiling, it is recommended that they be located to intersect column penetrations, since movement of columns can impose stresses on the ceiling membrane.

Control Joints, when properly insulated and backed by gypsum base panels, have been fire-endurance tested and are certified for use in one- and two-hour-rated walls.

Installation

At control joint locations:

1. Leave a 13 mm (1/2") continuous opening between gypsum boards for insertion of surface-mounted joint.
2. Interrupt wood floor and ceiling plates with a 13 mm (1/2") gap, wherever there is a control joint in the structure.
3. Provide separate supports for each control joint flange.
4. Provide an adequate seal or safing insulation behind control joints where sound and/or fire ratings are prime considerations.

Control Joint No. 093 Apply over the face of gypsum base where specified. Cut to length with a fine-toothed hacksaw. Cut end joints square, butt together and align to provide a neat fit. Attach the control joint to the gypsum base with Bostitch 14 mm (9/16") Type G staples, or equivalent, spaced 150 mm (6") o.c. max. along each flange. Remove the plastic tape after finishing with veneer plaster.

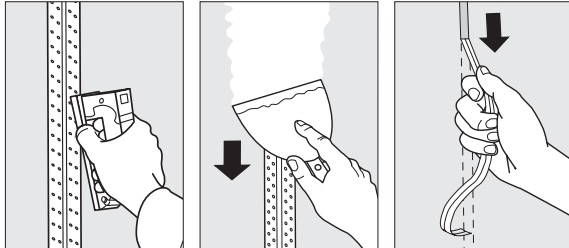

Control Joint No. 093 stapled, finished, tape removed.

Fire-Rated Control Joints-Gypsum Drywall/Steel Stud Partition

**47 STC
(SA-860302);
2-hr. Fire Rating**

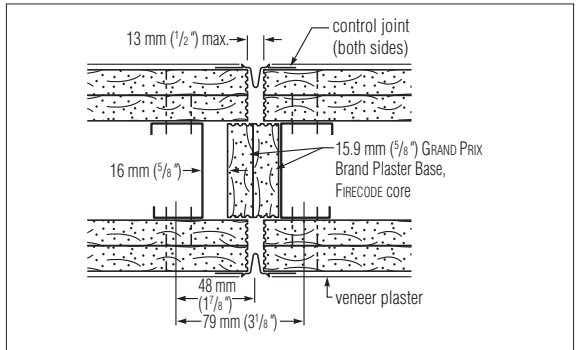

1-hr. Fire Rating

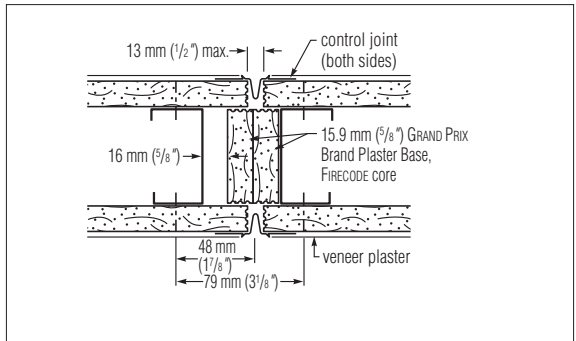

6

Control Joint No. 093

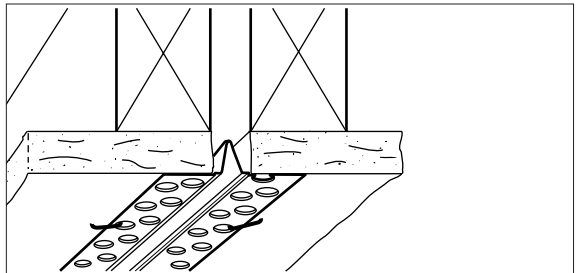

Maximum Spacing-Control Joints

Construction & Location	Max. Single Dimension	
	m	ft.
Partition-interior	9	30
Ceiling-interior		
with perimeter relief	15	50
without perimeter relief	9	30
Ceiling-exterior gypsum	9	30

Joint Treatment and Surface Preparation for Veneer Plaster Construction

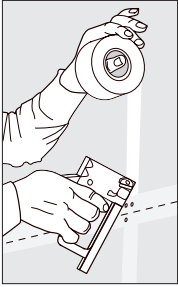

Simplified, wrinkle-free attachment of self-stick Type P IMPERIAL Brand Tape speeds joint reinforcing, boosts production.

For Wood-Framed Assemblies and Normal Drying Conditions

Align IMPERIAL Brand Type P (pressure-sensitive) Tape over joint and press into place over entire length. Eliminate wrinkles and assure maximum adhesive bond by pressing entire length of tape with steel finishing knife or trowel. Press tape into corners with corner tool; do not overlap.

Embed tape and fill beads with a coat of veneer plaster being used, and allow to set—but not dry—prior to veneer plaster application. Slightly underfill in the bead by screeding along the bead with edge of trowel after setting the bead. (Best results are obtained by planning the finishing to permit continuous application from angle to angle.)

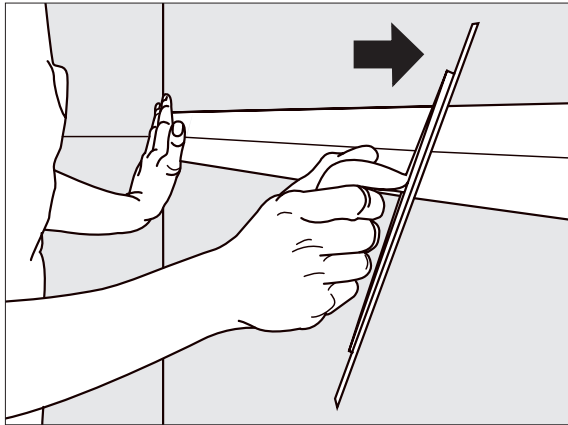

For Steel-Framed Assemblies and Rapid Drying Conditions

With steel framing and/or when building temperature-humidity conditions fall in the 'rapid drying' area of the graph for steel or wood framing (see page 199), use CGC Drywall Paper Tape embedded with DURABOND 45 or 90 Joint Compound.

Mix the compound in a clean 20 L container (plastic is preferred for setting type compounds). Use a commercial handmixer (commonly called a potato masher) or a 13 mm (1/2") heavy-duty 200 to 300-rpm electric drill with a drywall blade-type mixing paddle. Drill speed must not exceed 400 rpm. Use the amount of water shown on the bag and always sift the powder into the water to ensure complete wetting. Stir according to directions on bag.

Note: Do not contaminate compound with other materials, dirty water or previous batches. Do not retemper batches.

Butter joints with compound using a trowel or steel finishing knife to force compound into the joints. Center CGC Drywall Paper Tape over joint and press it into the fresh compound with trowel held at a 45° angle. Draw trowel along joint with sufficient pressure to remove excess compound.

After tape is embedded, apply a thin coat of joint compound to reduce possibility of edge wrinkling or curling. Allow thin coat to harden, then apply a fill coat completely covering the tape and feathering 75 mm (3") to 100 mm (4") beyond edges of tape. Allow to harden before finishing. Plaster prefill is not required over DURABOND compound.

Note: Under the following conditions DURABOND Drywall Compound and CGC Drywall Paper Tape must be used:

1. where two-coat finish is applied over 12.7 mm (1/2") or 15.9 mm (5/8") base on 600 mm (24") o.c. framing;
2. where one-coat DIAMOND Brand Interior Finish Plaster or IMPERIAL Brand Finish Plaster is applied over 15.9 mm (5/8") base on 600 mm (24") o.c. framing;
3. where IMPERIAL Brand Gypsum Base and veneer plaster is used over steel framing.

For Cement Board Substrate Prior to treatment of DURACK Brand Cement Board panel joints, apply CGC Plaster Bonder in a continuous film to the joint area according to application directions. Joints should then be treated with CGC Drywall Paper Tape and DURABOND compound. Mix and apply following directions on the bag. When the joints are completely dry, treat the entire wall surface with CGC Plaster Bonder according to application directions. Then apply DIAMOND Brand Veneer Basecoat Plaster and IMPERIAL Brand Finish Plaster in a two-coat application.

For Gypsum Fiber Bases This assembly provides added abuse-resistant characteristics when completed. Joints of FIBEROCK Brand Gypsum Panels must be treated with CGC Drywall Paper Tape and DURABOND compound following directions on the bag. When the joints are completely dry, treat the entire wall surface with CGC Plaster Bonder according to application directions. Then apply DIAMOND Brand Veneer Basecoat Plaster and IMPERIAL Brand Finish Plaster in a two-coat application.

For Improved Bond Several products are available to help setting-type joint compounds and veneer plasters work better. CGC Plaster Bonder, used on concrete, cement board, gypsum fiber panels and dry setting-type joint compound surfaces, enhances the plaster's ability to bond to those surfaces. CGC Plaster Accelerator-Alum Catalyst also can be used in a solution applied to the substrate surface to help lime-containing veneer plaster adhere to sun-faded plaster base surfaces or setting-type compound at joints (see page 360).

For Changing Working Time To alter the setting time of DURABOND compound CGC High Strength Accelerator also may be used as a mix additive to reduce the setting time, or CGC High Strength Retarder to extend the setting and working time.

Veneer Plaster Finish Applications

Veneer Plaster Systems		Veneer plaster can be applied over a variety of substrates in both one- and two-coat systems.								
Product Compatibility Selector	Substrate			Finish Plaster						
	Basecoat Plaster	CMU	Mono Concrete ⁽¹⁾	DUROCK [®]	GRAND PRIX Veneer Plaster Base	Gauging/ Lime	Gauging/ Lime/Sand	IMPERIAL Finish	DIAMOND Veneer Plaster	FERROCK Brand Gypsum Panels ⁽¹⁾
IMPERIAL Veneer Basecoat	✓	✓		✓	✓	✓	✓	✓	✓	✓
DIAMOND Veneer Basecoat	✓	✓	✓	✓	✓	✓	✓	✓	✓	✓
IMPERIAL Veneer Plaster				✓						
DIAMOND Veneer Plaster		✓ ⁽²⁾		✓						

Notes: (1) A bonding agent must first be applied. (2) Job sanded. (3) CGC Plaster Bonder must first be applied. ✓ = Acceptable

Mixing and Proportioning

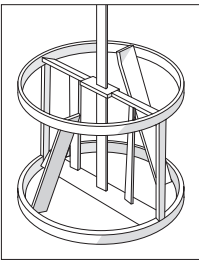

Cage-type mixing paddle is designed to draw material into and through paddle blades to disperse and blend ingredients by shear action rather than folding action of conventional mixers.

All veneer finishes require the addition of water on the job. Water should be clean, fresh, suitable for human consumption, and free from mineral and organic substances that affect the plaster set. Water used for rinsing or cleaning is not suitable for mixing because it accelerates the plaster set.

Mechanical mixing is mandatory for veneer finish plasters. Mix no more material than can be applied before set begins. Since veneer finishes set more rapidly than most conventional plasters, always consult bag directions for specific setting times.

Veneer plasters will produce mortar of maximum performance and workability when the correct equipment is used and mixing directions carefully followed. Proper mixing is one of the most important factors in producing mortar of maximum workability.

Use a cage-type mixer paddle driven by heavy-duty 13 mm (1/2") electric drill with a no-load rating of 900 to 1,000 rpm. Do not use propeller-type paddle or conventional mortar mixer. (For details of the cage-type mixing paddle and available electrical drills, see pages 400-401 and PM19, *Mixing Equipment for Veneer Plasters*.)

Mix plaster in 60 or 115 L smooth-sided container strong enough to withstand impacts that could cause gouging. Do not use brittle containers for mixing.

Correct mixing—rapid and with high shear action—is essential for proper dispersion of plaster ingredients. Slow mixing can reduce plasticity of material. Overmixing can shorten working time. Operated at correct speed, the cage-type design paddle mixes thoroughly without introducing excess air into the mix.

Mixing IMPERIAL Brand Plasters

Water requirements for IMPERIAL Brand Veneer Plasters:

IMPERIAL Brand Basecoat Plaster—5 to 6 L/22.5 kg (50 lb.) bag.

IMPERIAL Brand Finish Plaster—6.5 to 7.5 L/22.5 kg (50 lb.) bag.

Place water in a 45 to 60 L smooth-sided container. Start mixer, slowly add plaster and mix at least 2 min. to disperse lumps completely. Do not mix more than 5 min.

For sand float finish, add up to 5.5 kg (12.5 lb.) clean silica sand per 22.5 kg (50-lb.) bag of IMPERIAL Brand Plaster to achieve desired texture. The use of more than 5.5 kg (12.5 lb.) of sand per bag will decrease hardness of surface. (Apply plaster in normal manner but omit final troweling. After surface has become firm, float to desired texture, using sponge, carpet or other float. Use water sparingly.)

Mixing DIAMOND Brand Plasters

Water requirements for DIAMOND Brand Veneer Plasters:

DIAMOND Brand Veneer Basecoat—5.5 to 6.5 L/22.5 kg (50 lb.) bag.

DIAMOND Brand Interior Finish Plaster—11 to 14 L/22.5 kg (50 lb.) bag.

Place all but (1 or 2 L) of water into mixing container; then with mixer operating, slowly add one bag of material. If a texture finish is desired, up to 23 kg (50 lb.) clean silica sand may be added per 22.5 kg (50 lb.) bag of DIAMOND Brand Interior Finish Plaster. For electric cable heat systems, clean, sharp, fine silica sand must be added as follows: fill coat, 23 kg (50 lb.) but no less than 11 kg (25 lb.) per 22.5 kg (50 lb.) bag DIAMOND Brand Interior Finish Plaster; finish coat, at least 6 kg (12-1/2 lb.) per 22.5 kg (50 lb.) bag plaster. When material is wetted, add more water (1 or 2 L) to obtain desired consistency. Mix for minimum of two minutes, but no longer than five minutes.

When DIAMOND Brand Finish Plaster is job-aggregated, 15 ml (one table spoon) Cream of Tartar or 1 to 2 ml (1/4 to 1/2 teaspoon) of CGC Retarder for Lime Containing Plaster Products should be added for each bag of plaster to retard set and allow sufficient working time.

Application

Maintain temperature in all work areas at min. 13 to 16°C (55 to 60°F). Keep air circulation at minimum level during and after application until finish is dry.

IMPERIAL Brand Plasters

Hand Application—Embed IMPERIAL Brand Tape, Type P and fill beads with a tight, thin coat of IMPERIAL Brand Plaster; allow to set, then plaster (See “Selection of Joint Treatment System” on page 200.)

Plaster Finishing

IMPERIAL Brand Plasters offer a wide range of finish options with three distinct systems:

1. IMPERIAL Brand Finish Plaster (one-coat)
2. IMPERIAL Brand Basecoat Plaster with selected hand-applied or spray finish (two-coat).

IMPERIAL Brand Finish Plaster (one-coat) Scratch in a tight, thin coat of IMPERIAL Brand Finish Plaster over entire area, immediately doubling back with plaster from same batch to full thickness of 1.6 to 2.4 mm (1/16” to 3/32”). Fill all voids and imperfections. Final trowel after surface has become firm, holding trowel flat and using water sparingly. Do not overtrowel.

For texture finished surfaces, with or without the addition of job-added sand, final troweling is omitted. The surface is textured naturally as the material firms and water is removed into the base.

Best results are obtained by planning the plastering to permit continuous application from angle to angle. Where joining is unavoidable, use trowel to terminate unset plaster in sharp clean edge—do not feather out. Bring adjacent plaster up to terminated edge and leave level. Do

not overlap. During finish troweling, use excess material to fill and bridge joining.

IMPERIAL Brand Basecoat Plaster (two-coat) Scratch in a tight, thin coat of IMPERIAL Brand Basecoat Plaster over entire area, immediately doubling back with plaster from same batch to full thickness of 1.6 to 2.4 mm (1/16" to 3/32"). Fill all voids and imperfections. Leave the surface rough and open by cross-raking with a fine-wire rake or broom to provide proper bond of the finish coat. Allow the basecoat to set and partially dry to provide proper suction for the finish coat. If basecoat has dried, you may dampen (not saturate) the surface with water by means of a tank sprayer to control suction.

Finish coat materials are applied by scratching in and doubling back with selected finish—IMPERIAL Brand Finish Plaster, DIAMOND Brand Interior Finish Plaster, gauged lime-putty, to achieve a smooth, dense surface for decoration, free of surface blemishes. For textured finishes, floating on textures with additional material is conducted once the surface has become firm, using water sparingly.

**Other IMPERIAL
Brand Basecoat
Applications**

Concrete Block Surface must be porous for proper suction or be roughened/face-scored to provide adequate mechanical bond. Lightly spray walls with water to provide uniform suction. Fill and level all voids, depressions and joints with IMPERIAL Brand Basecoat Plaster and allow to set; then apply a subsequent coat, as with gypsum base application, leaving final surface rough and open to provide proper bonding of the finish coat.

Monolithic Concrete Prepare surface with CGC Plaster Bonder applied according to application directions. Fill all voids and depressions with IMPERIAL Brand Basecoat Plaster and allow to set and partially dry. Then apply IMPERIAL Brand Basecoat Plaster as with gypsum base or concrete block. Important: It is essential that the applied basecoat surface be raked or broomed once the material has become firm for a rough and open surface in order to provide for proper suction for the finish material. Failure to do this may result in delamination of the finish material.

**Integral Plaster
Chalkboards**

Plaster chalkboards offer maximum freedom in design. There is no limiting sheet size as is the case with fabricated boards; therefore, entire walls can be utilized as chalkboards. Maintenance is accomplished as easily as with conventional fabricated chalkboards. (Requirements for control joints in chalkboard surfaces are the same as for other gypsum surfaces.)

**Chalkboard
with Steel-Stud
IMPERIAL Brand
Gypsum Base
Partitions**

Follow directions for system construction. Locate floor and ceiling runners and position studs 406 mm (16") o.c. Attach IMPERIAL Brand Gypsum Base using 25 mm (1") TYPE S Screws spaced 16" o.c. When chalkboard area does not extend from floor to ceiling, use plaster "J" or "L" Trim to frame the GRAND PRIX Brand Gypsum Base face layers that will be used as chalkboard. (All chalkboard surfaces must have two layers of GRAND PRIX Brand Gypsum Base.) Miter corners of the metal trim to form a neat joint. Attach chalkboard using 41 mm (1-5/8") TYPE S Screws, driven through GRAND PRIX Brand Gypsum Base layer into the studs.

Veneer Plaster Application: use one or two-coat plaster for chalkboard surface. With one-coat work, apply IMPERIAL Brand Finish Plaster to 1.6 to 2.4 mm (1/16" to 3/32") thickness. Cover entire area with a tight, thin coat, then double back to full thickness. After surface has become firm, final-trowel to a smooth surface, using water sparingly.

For two-coat application, apply IMPERIAL Brand Basecoat Plaster to 1.6 to 2.4 mm (1/16" to 3/32") thickness as described for single-coat application. Allow basecoat to set and partially dry; then apply IMPERIAL Brand Finish Plaster. Leave surface very hard and polished.

Plaster chalkboard

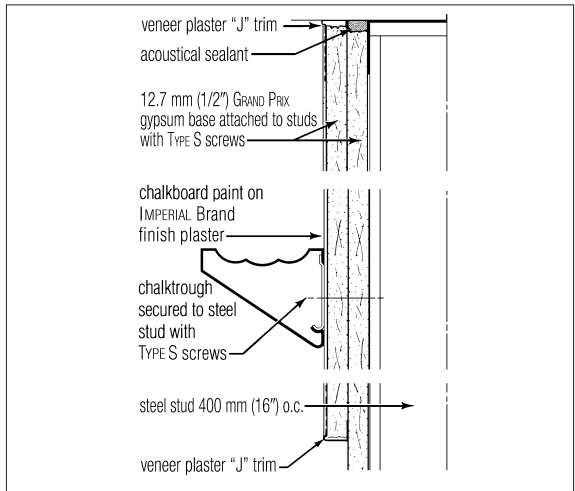

When dry, paint chalkboard with one coat primer-sealer and two coats chalkboard paint.

Install chalk trough with 33 mm (1-5/16") TYPE S Screws, driven through the two layers of IMPERIAL Brand Gypsum Base and into the steel studs.

DIAMOND Brand Plasters

DIAMOND Brand Interior Finish Plaster

All finish materials and finish surfaces must be protected from contact with DIAMOND Brand Interior Finish Plaster. This includes glass, ceramic materials, metal and wood. Apply wood, plastic or other exposed trim after plaster application.

DIAMOND Brand Interior Finish Plaster should be applied to GRAND PRIX Plaster Base having unfaded blue face paper. However, under abnormal conditions where there is no alternative to using GRAND PRIX Plaster Base faded from excessive exposure to sunlight or ultra-violet radiation, precautions should be taken to prevent delamination. Degraded GRAND PRIX Plaster Base is indicated if face paper is not blue or grayish blue. When face paper color has become gray to tan (or if questionable), treat paper with a solution of CGC Accelerator—Alum Catalyst or CGC Plaster Bond.

Degrading may occur when GRAND PRIX Plaster Base has been installed long before the finish is applied.

When used with lime-containing plaster, such as DIAMOND Brand Interior Finish Plaster, sunfaded GRAND PRIX Brand Gypsum Base face paper should be treated with an Alum Solution or CGC Plaster Bonder.

For alum catalyst solution treatment, pour 1.4 kg (3 pounds) of alum catalyst slowly into 3.78 L (one gallon) of water and mix thoroughly. Allow the solution to stand until any undissolved material has settled, then strain the solution into tank-type sprayer (such as a garden sprayer). Spray the solution onto the faded GRAND PRIX Brand Base face paper so that it is wet but not soaked. 4 L of solution should treat 70 m² (750 sq. ft.) of GRAND PRIX Gypsum Base. Begin finish plaster application before face paper treated with alum solution is completely dry. Caution: Alum treatment shortens the setting time of DIAMOND Brand Interior Finish Plaster.

Begin application only after joints have been reinforced with glass fiber tape and preset with an application of DIAMOND Brand Interior Finish Plaster or treated with CGC Brand Paper Joint Tape and DURABOND Setting Joint Compound. Apply a thin, tight scratch coat of this finish over entire working area. Immediately double back with material from same batch to a full 1.6 to 2.4 mm (1/16" to 3/32") thickness.

Start the finish troweling as soon as material has become sufficiently firm to achieve a smooth trowel finish free from trowel marks, voids and other blemishes. Smooth and level the surface with trowel held flat; use water sparingly to lubricate. Final hard troweling should be accomplished prior to set as indicated by darkening of the surface.

A variety of textures ranging from sand float to heavy Spanish can be achieved with DIAMOND Brand Interior Finish Plaster when job-aggregated with silica sand. Application is the same as for neat DIAMOND Brand Interior Finish Plaster except that once the surface has been leveled and sufficient take-up has occurred, begin floating material from the same batch with trowel, float, sponge or by other accepted local techniques.

DIAMOND Brand Interior Finish Plaster also may be textured by skip-troweling. When applying in this manner, eliminate final troweling. When surface has become sufficiently firm, texture with material from same batch prior to set.

Painting or further decoration of DIAMOND Brand Interior Finish Plaster is recommended and should be specified. However, in many residential applications, DIAMOND Brand Interior Finish Plaster provides a uniform white color and may satisfy a job's specific acceptance criteria if skip-trowel and float-finish textured finishes are utilized. DIAMOND Brand Interior Finish Plaster is formulated to allow quick drying and can be decorated when thoroughly dry using a latex base or breather-type paint. Under ideal conditions, painting can take place in as little as 24 hours, which minimizes costly delays and speeds occupancy.



Graceful, wavelike swirl texture



Light to medium skip trowel texture



Sand-aggregated float finish

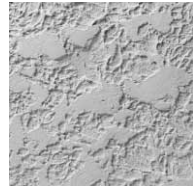

Heavy texture finish (Spanish)

DIAMOND Brand Veneer Basecoat Plaster

DIAMOND Brand Veneer Basecoat Plaster provides quality walls and ceilings for residential construction where the superior strength of IMPERIAL Brand Basecoat Plaster is not essential. DIAMOND Brand Veneer Basecoat Plaster produces a base that esthetically enhances the finish by providing regulated suction, resulting in exceptional integral bond. Once basecoat is applied and has become firm, surface is raked or broomed to provide a rough and open surface for the finish coat. Be certain that the basecoat is not completely dry. The basecoat should be set and allowed to dry only partially to provide proper suction for the finish coat. If the basecoat has dried, you may dampen (not saturate) the surface with water by means of a tank sprayer to control suction.

Over Gypsum Base Apply DIAMOND Brand Veneer Basecoat Plaster from 1.6 to 2.4 mm (1-16" to 3/32") thickness. When GRAND PRIX Gypsum Base is used, reinforce all joints and interior angles with IMPERIAL Brand Type P Tape. Embed tape and fill beads with DIAMOND Brand Veneer Basecoat Plaster and allow to set, but not dry. After beads and joints have been properly prepared (rough and open), apply a tight, thin coat of DIAMOND Brand Veneer Basecoat Plaster over the entire area, immediately doubling back with plaster from the same batch to full thickness. Fill all voids and imperfections. Leave surface rough and open by cross raking with a fine wire rake, sponge or fine broom once the surface has become somewhat firm. Allow basecoat to set to provide proper suction for finish coat.

Over Concrete Block Surface must be porous and develop proper suction to provide adequate mechanical bond. Lightly spray walls with water to provide uniform suction. Fill and level all voids, depressions and joints with DIAMOND Brand Veneer Basecoat Plaster and allow to set; then apply subsequent coats as with gypsum base application, leaving final surface rough and open to provide proper bonding of the finish coat.

Over Monolithic Concrete Prepare surface with CGC Plaster Bonder applied according to application directions. Fill all voids and depressions with DIAMOND Brand Veneer Basecoat Plaster and allow to set and partially dry. Then apply DIAMOND Brand Veneer Basecoat Plaster as with gypsum base or concrete block. Important: It is essential that the applied basecoat surface be raked or broomed once the material has become firm for a rough and open surface to provide proper suction for the finish coat. Failure to do so may result in delamination of the finish material.

Painting of Veneer Plaster

No matter what paint or decoration is used, it is essential that the plaster be completely dry. Typically, veneer plasters may be dry in as little as 24 hours. Use a high-quality, undiluted acrylic latex, vinyl or alkali-resistant alkyd paint. Prior to the installation of an applied finish, such as epoxy-based finish systems, the veneer plaster must be properly sealed. Quick-drying vinyl acrylic latex or alkali-resistant alkyd primer-sealers are recommended. Polyvinyl acetate (PVA) based primers should not be used over wet plaster of any kind, including lime-containing plasters. The PVA film is subject to rewetting and will almost certainly cause bond loss and subsequent paint delamination.

*Trowel job-sanded
DIAMOND Brand Interior
Finish Plaster over
electric cable.*

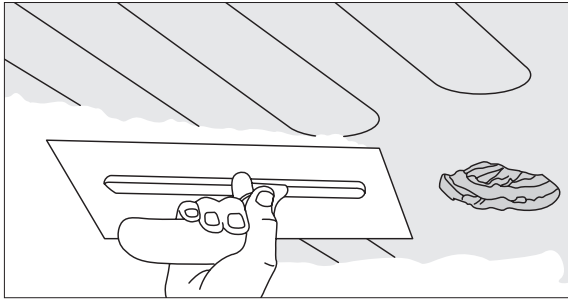

Radiant Heat Plaster System—DIAMOND Brand Interior Finish Plaster

Application—Radiant Heat Cable After GRAND PRIX Gypsum Base and joint reinforcement tape have been applied, install electric radiant heating cable in accordance with design requirements and cable manufacturer's specifications. Attach cable to ceiling in such a manner that it is kept taut and does not sag away from the base. All cable connectors and non-heating leads should be embedded (countersunk) into, but not through, the gypsum base so they do not project below the heating wire.

Fill Coat Application Apply job-sanded DIAMOND Brand Interior Finish Plaster in sufficient thickness to completely cover cable. Trowel plaster parallel to direction of cable but do not use cable as a screed. Level with a trowel, rod or darby to fill any low spots or to remove any high ridges, etc. Use a serrated darby or lightly broom the plaster surface prior to set to provide a key for the finish coat. Average thickness of fill coat should be 4.8 mm (3/16").

Finish Coat Application Apply finish coat after fill coat has developed sufficient suction—in good drying weather, about two hours after the fill coat has set; in damp or cold weather usually overnight unless good supplementary heat and ventilation are provided. Use job-sanded DIAMOND Brand Interior Finish Plaster 1.6 to 2.4 mm (1/16" to 3/32") thick, to bring total plaster thickness to 6.4 mm (1/4").

Scratch in a tight thin coat over the entire area, immediately doubling back to full thickness. Fill all voids and imperfections. Scratch and double-back with the same mix of DIAMOND Brand Interior Finish Plaster. When surface has become firm, hold trowel flat and final-trowel using water sparingly. Best results are obtained by continuous application of an entire ceiling. Always work to a wet edge to avoid dry joinings.

Texture Finish When finish coat has become sufficiently firm, but not set, float surface to desired texture using a sponge, carpet, or other float. Use water sparingly. For heavier texture, additional material from the same batch may be applied to the firm surface to achieve a skip-trowel, Spanish, or other texture.

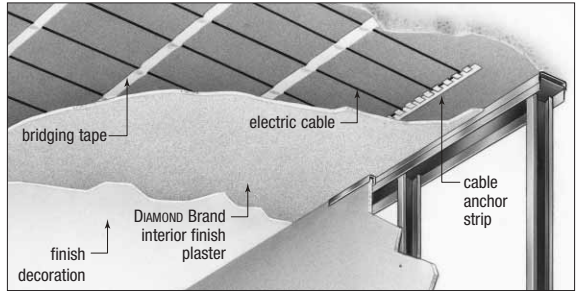

Radiant Heat Systems to Monolithic Concrete

Surface Preparation Concrete surface must be structurally sound and clean, free of dirt, dust, grease, wax, oil or other unsound conditions. Treat exposed metal with a rustproof primer. When corrosion due to high humidity and/or saline content of sand is possible, the use of zinc alloy accessories is recommended.

Remove form ridges to make surfaces reasonably uniform and level. Locate uneven ceiling areas and bad gravel pockets, which require filling prior to installing electric cable and filler.

After treating entire surface with CGC Plaster Bonder, according to application directions, leveling may be done with fill-coat mix of job sanded DIAMOND Brand Interior Finish Plaster. Minor leveling may be done with a DURABOND Setting-Type Joint Compound.

Caution: Temperature of concrete ceiling with bonding agent applied must be above 0°C (32°F) before filler and finish applications are started, with air temperature above 13°C (55°F).

Radiant Heat Cable Application After ceiling surface has been leveled, apply electric radiant heating cable according to design requirements and cable manufacturer's specifications. Attach cable to the ceiling so that it is kept taut and does not sag away from the ceiling. All cable connectors and non-heating leads must be securely attached to concrete ceiling.

Finishing Mix and apply job-sanded fill coat DIAMOND Brand Interior Finish Plaster according to directions in previous section. Apply 8 mm (5/16") basecoat parallel to direction of cable, completely covering cable and anchor devices.

Mix and apply finish coat after fill coat has developed sufficient suction. Use job-sanded **DIAMOND** Brand Interior Finish Plaster 1.6 to 2.4 mm (1/16" to 3/32") thick, to bring total plaster thickness to 10 mm (3/8"). Apply finish coat in same manner described in previous section.

Do not energize heating cable until plaster is thoroughly dry. When either or both the completed radiant heat ceiling and room temperature are below 13°C (55°F), the temperature should be increased in 3°C (5°F) increments for each 24-hr. period until a room temperature of 13°C (55°F) is attained.

If completed radiant heat ceiling and room temperature are 13°C (55°F) or higher, thermostat may be set at desired temperature.

Special Abuse Resistant Systems

Veneer Plaster Over Durock Brand Cement Board

For improved impact strength and abrasion resistance, a two-coat veneer plaster system consisting of **DIAMOND** Brand Veneer Basecoat Plaster and **IMPERIAL** Brand Finish Plaster is applied over **DUROCK** Brand Cement Board attached to framing. This construction is particularly useful for commercial and institutional applications such as schools and high-traffic retail locations.

Space wood or steel framing 400 mm (16") o.c. and install **DUROCK** Brand Cement Board with long edges either parallel or perpendicular to the framing and with the rough side of panels exposed. Fasteners are spaced a maximum of 200 mm (8") o.c.

Prior to treatment of panel joints, apply **CGC** Plaster Bonder in a continuous film to the joint areas according to application directions. Joints should then be treated with **CGC** Brand Paper Joint Tape and **DURABOND** Setting-Type Joint Compound. Joint surfaces must be treated with a separate coat of joint compound to fully conceal the paper tape.

When the joint is completely dry, treat the entire wall surface with **CGC** Plaster Bonder. Then apply **DIAMOND** Brand Veneer Basecoat Plaster from 1.6 to 2.4 mm (1/16" to 3/32") thickness using a scratch and double-back technique. When basecoat plaster is firm, broom the surface to leave it rough and open for a finish application. With basecoat set and partially dry, apply **IMPERIAL** Brand Finish Plaster using a scratch and double-back technique. Complete finishing when material is firm. Leave finished surface smooth and dense for decorating.

Veneer Plaster Over FIBEROCK Brand Abuse-Resistant Panels

The abuse resistant characteristics of already tough **FIBEROCK** Brand Abuse-Resistant Panels are enhanced with the application of a two-coat veneer plaster system. Panels are applied in the same fashion as for cement board above, then joints are treated using **SHEETROCK** Brand Paper Joint Tape and **DURABOND** Setting-Type Joint Compound. When the joints are completely dry, treat the entire wall surface with **CGC** Plaster Bonder according to the application directions. Then apply **DIAMOND** Brand Veneer Basecoat Plaster and **IMPERIAL** Brand Finish Plaster as described above for cement board.

Resurfacing Walls and Ceilings

Veneer plasters may be used to resurface walls that are damaged or walls that can benefit from a more abuse-resistant surface. However, care must be taken to prepare the wall surface for plaster application.

Make sure old wall coverings and their adhesives have been removed. Wash surface thoroughly. Scrape away any loose paint and remove and repair any damaged drywall or plaster surface with appropriate patching material. (See patch and repair products, page 55.) Fill all cracks or holes with DURABOND Setting-Type Joint Compound and SHEETROCK Brand Paper Joint Tape if necessary.

Once joint compound has set and dried, apply CGC Plaster Bonder over entire wall and ceiling area to be resurfaced.

Mix DIAMOND Brand Veneer Basecoat and Interior Finish Plaster as described on pages 206-207 and trowel-apply over surface using a scratch and double-back technique with each coat. Do not overtrowel.

Decorating with Pigmented Finish Plaster

Decorative Interior Finish System

The CGC Decorative Interior Finish System is applied to GRAND PRIX Gypsum Base. If SHEETROCK Brand Gypsum Panels or other approved substrate are used, the surface must be prepared with SHEETROCK Brand Wallcovering Primer and then with CGC Plaster Bonder to assure a consistent bond.

CGC Decorative Interior Finish consists of DIAMOND Brand Interior Finish Plaster mixed with pigments that will not affect plaster set. The system must be sealed upon completion.



Color is thoroughly mixed into the finish, providing a deep tinted layer that effectively hides mars, chips and scratches from appearing. High-quality colorants are used to assure color consistency and UV resistance. System identifies 12 basic colors that can be mixed using a standard tint machine and COLORTREND 888 Universal Machine Colorants. CGC recommends using only COLORTREND 888 Universal Machine Colorants. Colorants from other manufacturers are not recommended since they may not be compatible with CGC materials, they may cause color variations and they may interfere with the intended product application. We recommend only the use of COLORTREND 888 Universal Machine Colorants, the basic CGC color formulas with these colorants and custom colors created using the COLORTREND AMBIANCE™ Fan Deck Selector.

For standard colors using COLORTREND 888 Universal Machine Colorants, the formula selected will produce a 19 L batch size. To create a custom color, select a color and formula from the fan deck and color formula book that represents a color somewhat darker than the color you desire as the finished, dried, surface color. Note that the shade of finished colors is dependent on many factors. Each color formula yields a slightly different degree of color lightness compared to the color swatch depicted in the fan deck selector. The texture applied and the consistency of the mixed mortar also effect the appearance of the finished surface, and therefore the color. Even the plaster product chosen (DIAMOND Brand Interior Finish, IMPERIAL Brand Basecoat Plaster, DIAMOND Brand Veneer Basecoat Plaster or IMPERIAL Brand Finish Plaster) for the mix can vary the resulting shade. Depending on these factors, the final dried finish can be up to several shades lighter than the color swatch depicted in the fan deck selector. Note also that when wet, the wet mixed mortar appears darker than the selected color swatch, but will lighten in color when set and dry.

Mixing CGC Decorative Interior Finish usually consists of DIAMOND Brand Interior Finish mixed with colorants and water, but IMPERIAL Brand Basecoat Plaster, DIAMOND Brand Veneer Basecoat Plaster or IMPERIAL Brand Finish Plaster also may be used. Mix in 19 L pail (356 mm (14") high, 260 mm (10-1/4") bottom, 286 mm (11-1/4") top). Use 165 mm (6-1/2") of water per batch for DIAMOND Brand Interior Finish, 114 mm (4-1/2") for DIAMOND Brand Veneer Basecoat Plaster, 102 mm (4") for IMPERIAL Brand Basecoat Plaster, and 127 mm (5") for IMPERIAL Brand Finish Plaster. Add the predetermined amount of colorant (COLORTREND Formula) to the water.

The plaster is added to the water in three stages. First, fill the bucket with plaster and stir lightly with an on-and-off action using a 450 RPM 13 mm (1/2") drill and blade-type (joint compound) mixing paddle. Add plaster to the top of the bucket and repeat stirring with on-and-off action. Add plaster a third time and mix completely, ensuring that no colored water splashes out of mixing container.

Mix approximately 18-20 kg (40-45 lbs.) of DIAMOND Brand Interior Finish with the water, or 27 kg (60 lbs.) of DIAMOND Brand Veneer Basecoat Plaster or IMPERIAL Brand Basecoat Plaster, or 23 kg (50 lbs.) of IMPERIAL Brand Finish Plaster. These quantities should fill the container to about 25 to 38 mm (1 to 1-1/2 inches) from its top. Finish

should be slightly thicker than normal. To ensure color uniformity, each batch must be mixed exactly the same way, by volume and to the same fluidity in a volume-specific container. Note that graded white silica sand may be used for float finishing.

Application Each wall or ceiling must be covered in a continuous application, always continuing joinings of separate mixes prior to either mix setting. Work walls and vaulted ceilings from top to bottom; ceilings from angle to angle. For one-coat semi-smooth texture, apply plaster in random, 300 to 600 mm (1' to 2') strokes at a nominal 1.6 to 3 mm (1/16" to 1/8") thickness, leaving lap marks as desired. After approx. 20 min. from initial application, draw a trowel, held almost flat, lightly over the surface with short strokes in various directions. Trowel again as initial set begins (approx. 45 min.). For two-coat heavy texture, apply first coat to a nominal thickness of approx. 3 mm (1/8"), covering the entire surface. When surface has firmed slightly, apply second coat in short strokes as described above. Two-coat thickness should vary from 3 to 6.4 mm (1/8" to 1/4"). Additional troweling of second coat should be as described above for one-coat finish.

Sealing After finish has set and dried (approx. 24 hr.), apply CGC Decorative Finish Sealer and maintain min. 13°C (55°F) temperature. Do not shake or box-mix sealer. Apply using brush, roller or sprayer with 0.4 to 0.6 mm (0.015" to 0.023") tip. Initially, sealer will appear milky, but will dry clear and colorless. When appearance changes to clear, wipe or roll drips and puddles, then recoat.

