



CGC DUROCK® BRAND SCREWS

DATA SHEET



CGC DUROCK® BRAND SCREWS ARE HIGH-QUALITY, CORROSION-RESISTANT FASTENERS SPECIALLY DESIGNED FOR ATTACHING VARIOUS TYPES OF BACKERBOARDS AND UNDERLAYMENTS TO WOOD OR STEEL FRAMING MEMBERS

- Can be used for interior and exterior applications.
- Corrosion-resistant coating. Designed to resist 1500+ hours of salt-spray testing before developing 5% red rust (per ASTM B117).
- The RECEX® Robertson/Phillips combo drive produces a cling fit that reduces driving effort, promotes faster driving and extends bit life.
- Features a large wafer-type head that provides exceptional holding power.
- Strip-out prevention ribs prevent “pull through.”
- Two thread designs are available: a coarse hi-lo Aster thread design for wood framing and a self-drilling thread design for 14 to 20 gauge metal stud thicknesses.
- The blue colour offers better visual contrast when fastening panels.
- Conveniently packaged for small and medium size installations in a clear and durable plastic jar that includes a square bit. The jars feature twist-on lids with handles and can easily be repurposed or recycled.

INSTALLATION

- Use minimum 4-amp or cordless screw gun capable of achieving 1500-2500 rpm.
- Bit compatibility: #2 square drive or Phillips #2 drive.
- Apply screws 9.5 mm (3/8") to 15.9 mm (5/8") from edges of panels.
- Screw spacing is 200 mm (8") o.c. for walls and floors and countertops, 150 mm (6") o.c. for ceilings.
- Install screws with screw-heads flush with the panel surface. Do not countersink screws.
- Screws must be driven straight to assure optimal performance.

RECOMMENDED APPLICATIONS

WOOD FRAMING	FLOOR/COUNTERTOP	WALL	CEILING	UNDERLAYMENT/ BACKERBOARD THICKNESS
1-1/4" CGC Durock® Screw for wood framing	X	X	—	6.3 mm (1/4"), 9.5 mm (3/8"), 12.7 mm (1/2") and 15.9 mm (5/8")
1-5/8" CGC Durock® Screw for wood framing	—	X	X	12.7 mm (1/2"), 15.9 mm (5/8")
STEEL FRAMING	FLOOR/COUNTERTOP	WALL	CEILING	BACKERBOARD THICKNESS
1-1/4" CGC Durock® Screw for steel framing	—	X	X	12.7 mm (1/2"),
1-5/8" Durock® Screw for steel framing	—	X	X	15.9 mm (5/8")

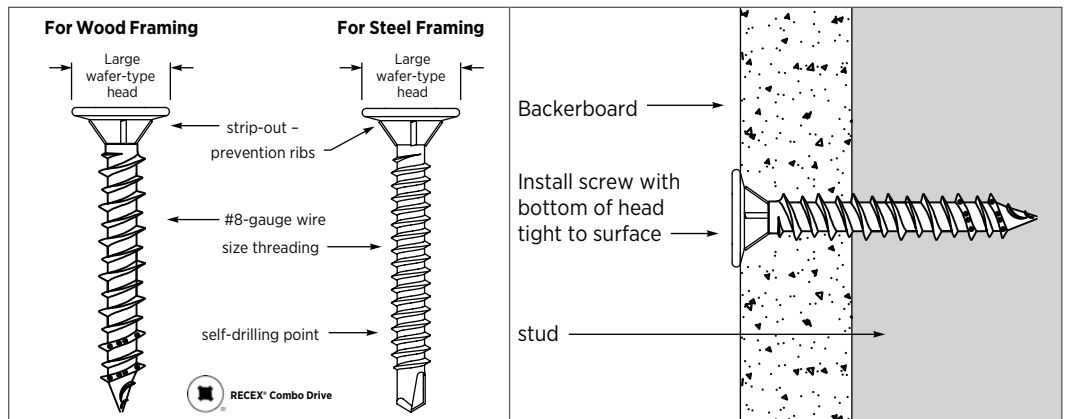



SIZES AND PACKAGING

WOOD FRAMING (WHITE LID JAR)

STEEL FRAMING

	UNIT SIZE	UNITS PER CARTON
1-1/4" CGC DUROCK® SCREW FOR WOOD FRAMING 200	200 PCS/JAR	18 JARS/CTN
1-1/4" CGC DUROCK® SCREW FOR WOOD FRAMING 600	600 PCS/JAR	10 JARS/CTN
1-1/4" CGC DUROCK® SCREW FOR WOOD FRAMING BULK	5,000 PCS	5,000 PCS/CTN
1-5/8" CGC DUROCK® SCREW FOR WOOD FRAMING 350	350 PCS/JAR	10 JARS/CTN
1-1/4" CGC DUROCK® SCREW FOR STEEL FRAMING BULK	5,000 PCS	5,000 PCS/CTN
1-5/8" CGC DUROCK® SCREW FOR STEEL FRAMING BULK	4,000 PCS	4,000 PCS/CTN

TRADEMARKS:

The CGC logo is a trademark of CGC Inc. CGC Inc. is a licensed user of the following trademark: CGC Durock. RECEX is a trademark owned by Robertson/Pan American Screw.

NOTE:

Products described here may not be available in all geographic markets. Consult your CGC sales office or representative for information.

NOTICE:

We shall not be liable for incidental and consequential damages, directly or indirectly sustained, nor for any loss caused by application of these goods not in accordance with current printed instructions or for other than the intended use. Our liability is expressly limited to replacement of defective goods. Any claim shall be deemed waived unless made in writing to us within thirty (30) days from date it was or reasonably should have been discovered.

SAFETY FIRST!

Follow good safety and industrial hygiene practices during handling and installing all products and systems. Take necessary precautions and wear the appropriate personal protective equipment as needed. Read material safety data sheets and related literature on products before specification and/or installation.

