

# Pixels™

## Wall Mounted



# Design and Installation Guide

December 2012



**On the cover:** PIXELS mural shown with GE Tetra® Power Grid during installation.  
For more information go to [gelightingsolutions.com](http://gelightingsolutions.com)

# Design and Installation Guide

Pixels™ wall-mounted Celebration™ panels from USG offer a turnkey system for displaying the unique perforated imagery art that Pixels makes possible.

	Pages		
<b>Planning Your System</b>	<b>2</b>	<b>Overview— Wall-Mounted Systems</b> <b>PIXELS Panels</b> <b>Design Elements</b>	
<b>Surface-Mounted Application (Non-Backlit)</b>	<b>8</b>	<b>Components</b> <b>Construction</b> <b>Installation</b>	
<b>Frame-Mounted Application (Backlit)</b>	<b>17</b>	<b>Components</b> <b>Construction</b> <b>Installation</b>	
<b>Appendix</b>	<b>30</b>	<b>Shop Drawings</b> <b>USG/GE Power Grid System Modules</b>	
<b>For More Information</b>		<b>Technical Service</b> <b>800.USG.4YOU</b>	<b>Web Site</b> <b>usg.com</b>

# System Overview

---

## Pixels Wall-Mounted Applications

---

### Features

CELEBRATION™ panels and CELEBRATION panels with PIXELS™ imagery can be mounted to the vertical surface in two ways: directly to the surface using wall mount backer board system, or away from the vertical surface leaving a “cavity” in which to mount light sources for back lighting the image. Here are examples of each application.

---

### Surface Mounted

This backer board system is simple in both design and application while providing a hard surface directly behind the CELEBRATION panel thus improving durability.



# System Overview

---

## Pixels Wall-Mounted Applications

---

### Frame Mounted

The backlit system is also simplified in that it uses standard FINELINE® suspension – only mounted to the wall thus being quite familiar to contractors.



---

On the pages that follow, further explanation of the systems will clarify, in detail, how each can be used effectively depending on the design criteria and desired result.

---

An example of PIXELS frame-mounted backlit installation with GE Tetra® PowerGrid is on display at GE Lighting & Electrical Institute at historic Nela Park, Cleveland, OH (photo above)

# System Overview

## Design Elements

### Shape

The overall shape of a wall-mounted system is determined by the size of the panels and their configuration and relationship to one another.

Available panel sizes are

- 2' x 2'
- 2' x 4'
- 2' x 6'

### Panels

2' x 2' PIXELS CELEBRATION Panel

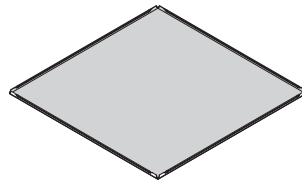

2' x 4' PIXELS CELEBRATION Panel

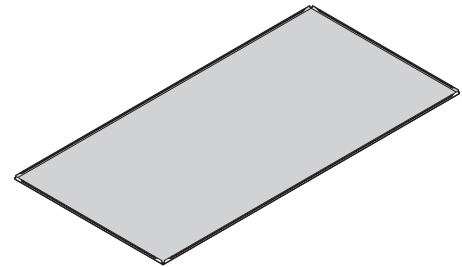

2' x 6' PIXELS CELEBRATION Panel

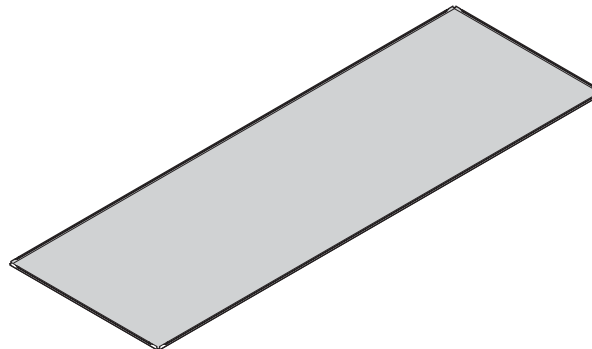

**Note:** The PIXELS image and design process itself is detailed in the PIXELS Design Guide, IC566. Through that process the panels are ordered separately from the wall mount system.

# System Overview

## Design Elements

The PIXELS panels can be arranged in any number of creative ways. As long as the 2' module dimension is honored, almost any configuration can be achieved including altering the shape of the frame itself.

### Sample Configurations

#### 6' x 4' System

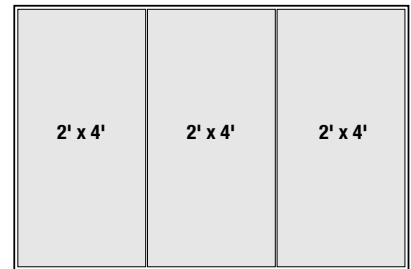
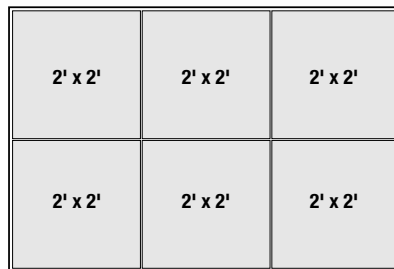

#### 8' x 4' System

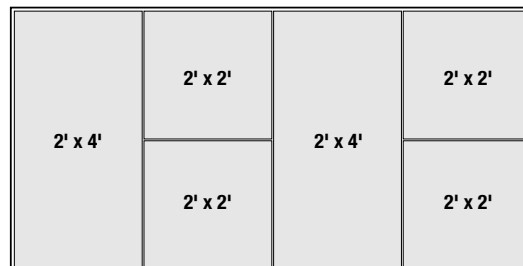

# System Overview

## Design Elements

### Sample Configurations

#### 6' x 6' Systems

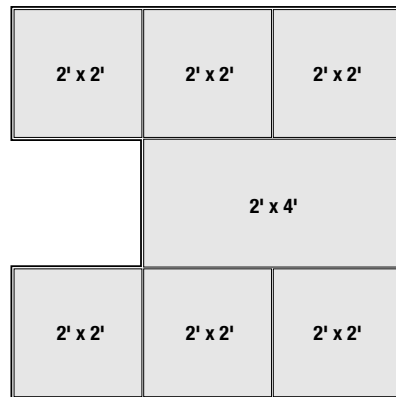
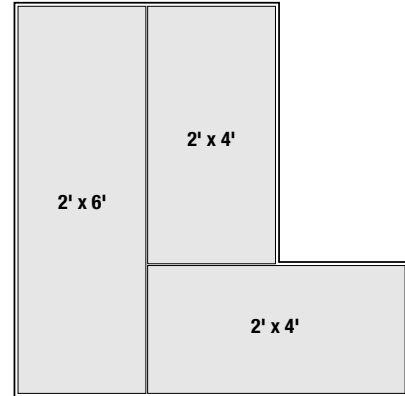
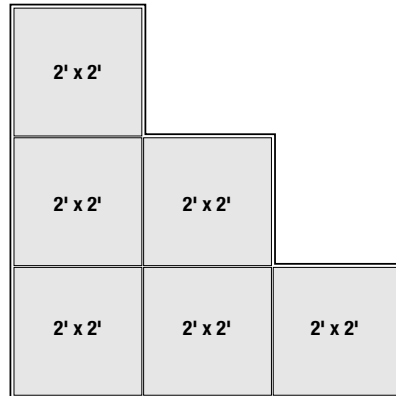

There is no limitation to the finished size of the system. The above examples are only to show the flexibility of panel layout and frame configuration.



# System Overview

## Design Elements

Photos can be used as is or combined with copy or graphics. Also see PIXELS Design Guide (IC566) for a further understanding of PIXELS graphics capabilities.

2' x 4' configuration

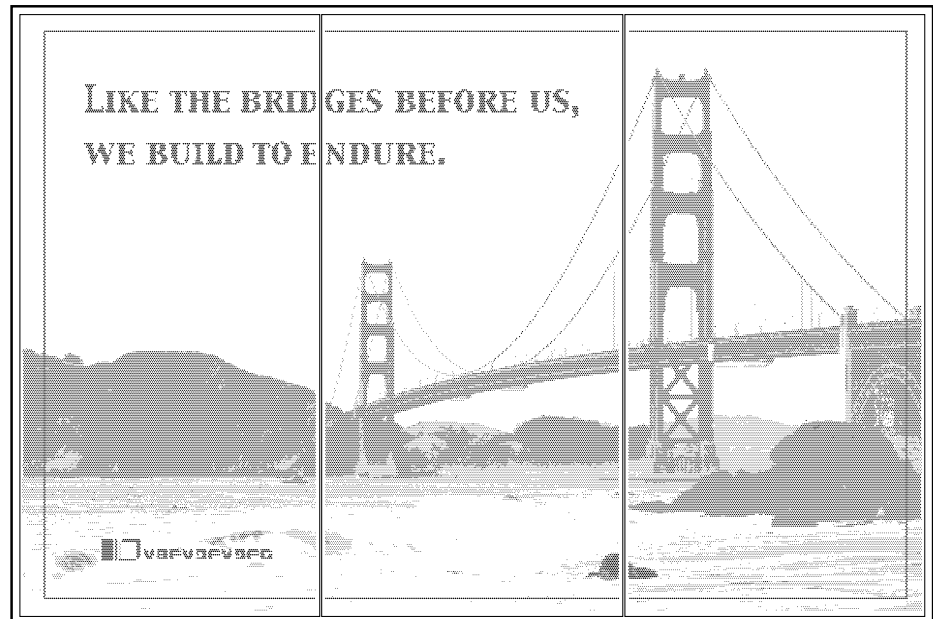
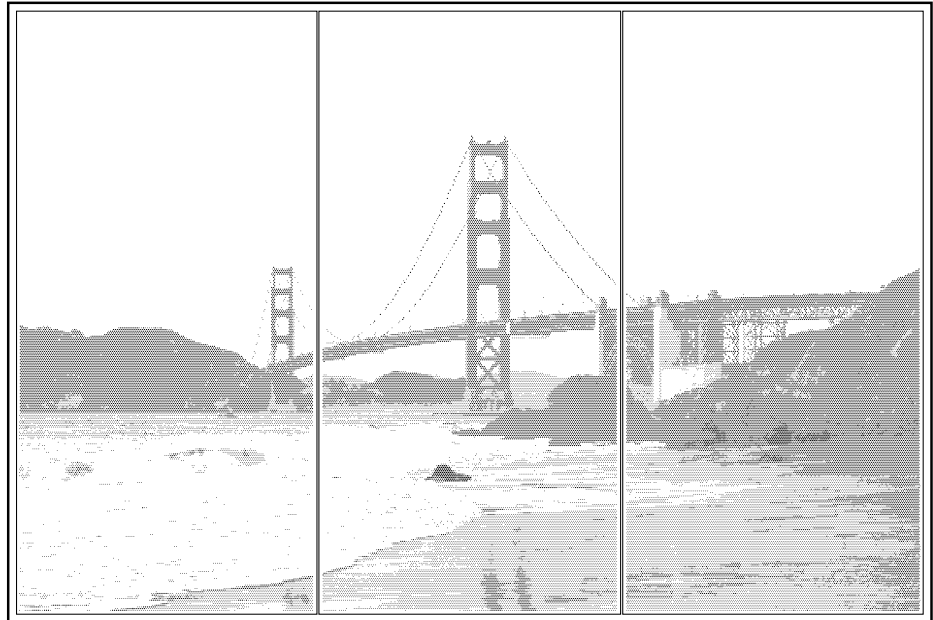

# Surface-Mounted System

## Components

In addition to the PIXELS CELEBRATION panels (see page 4), the following components are unique to the surface-mounted system.

### Surface-Mounted Backer Boards

2' x 2' (WMBB24)

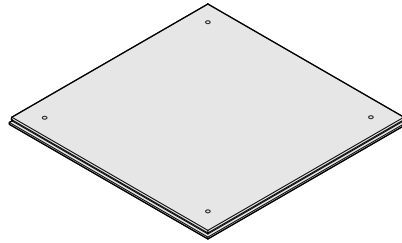

2' x 4' (WMBB48)

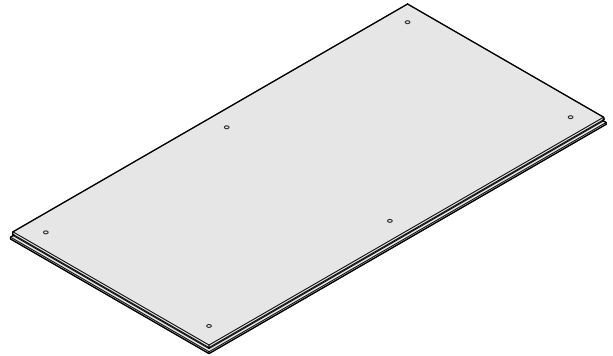

2' x 6' (WMBB72)

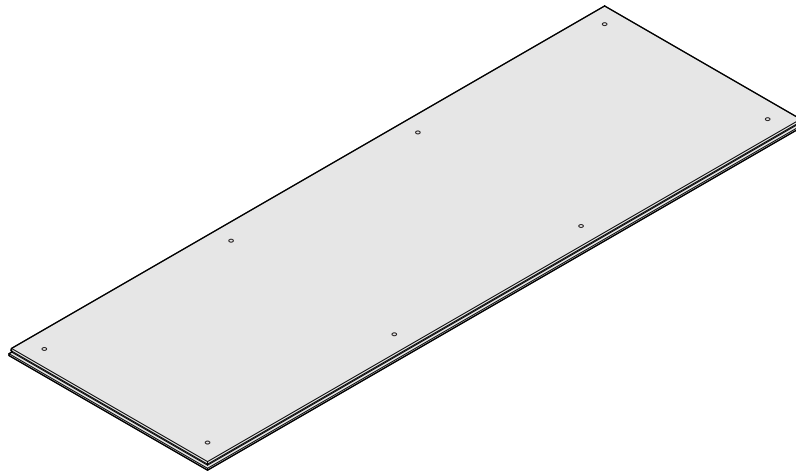

### Construction Detail

#### Backer Board Edge Profile

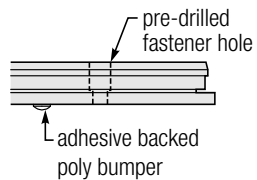

# Surface-Mounted System

---

## Components

Edge Trim

Backer Board Aluminum Trim

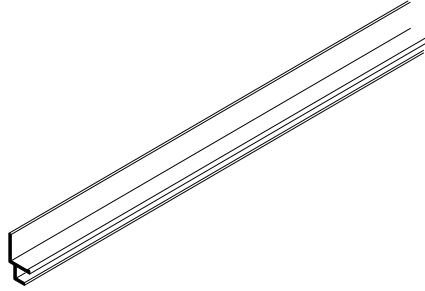

Fastener

Wall-Dog™ Fastener

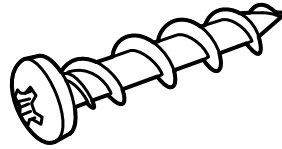

**Note:** Wall-Dog is a trademark of Powers Fasteners, Inc. For more information please visit [www.powers.com](http://www.powers.com)

# Surface-Mounted System

## Construction

The surface-mounted system consists of backer panels that are installed edge-to-edge directly to the wall surface.

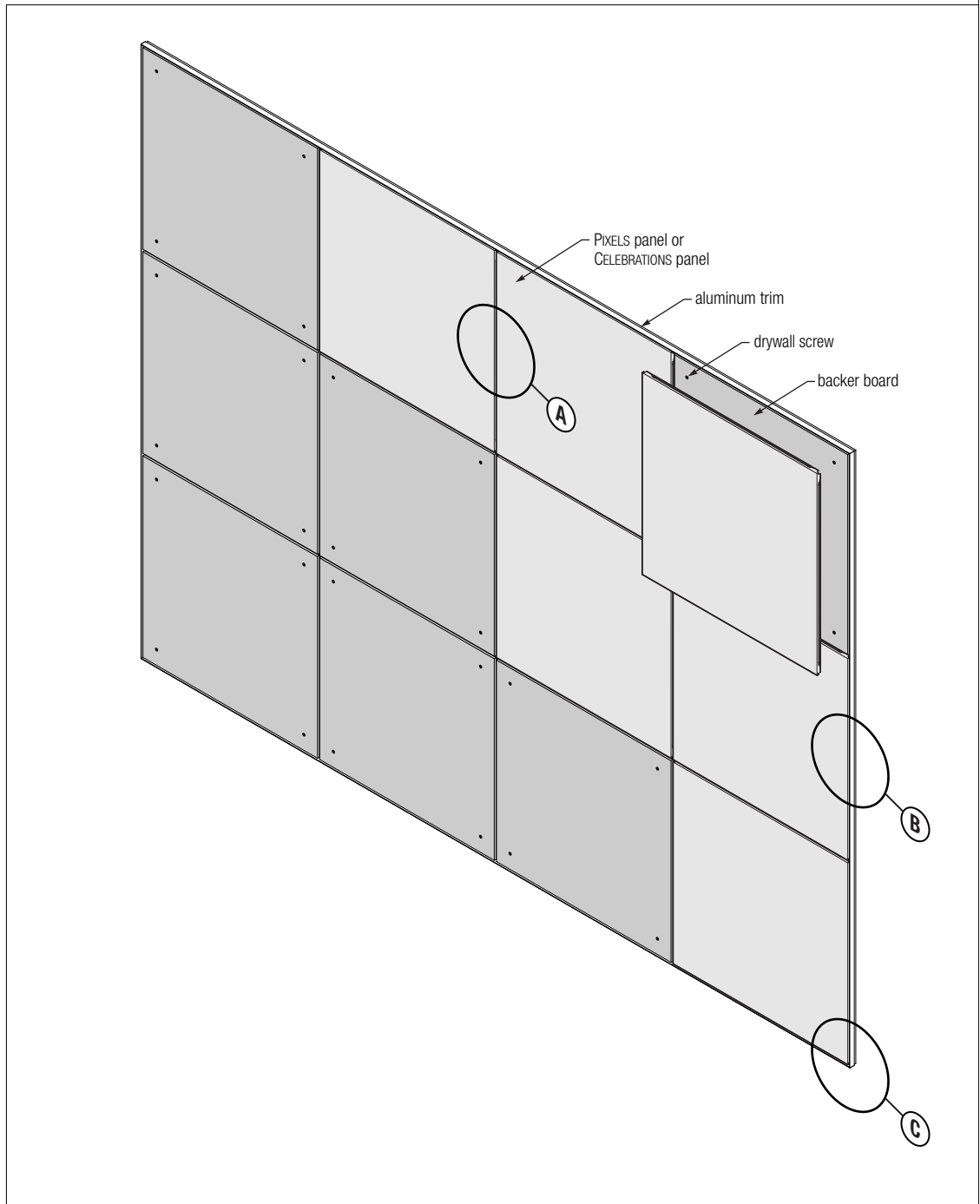

# Surface-Mounted System

## Construction

### Construction Details

#### A. Panel Intersection

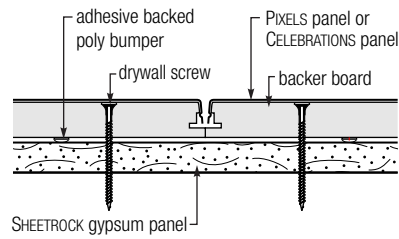

#### B. Perimeter Edge

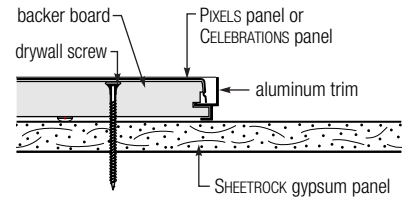

#### C. Corner

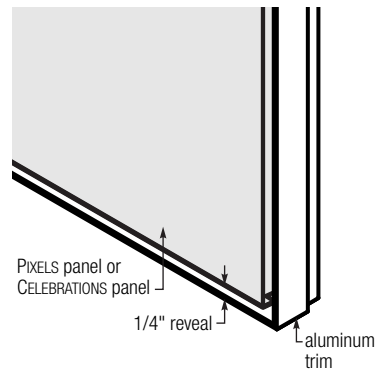

# Surface-Mounted System

## Installation

**Note:** These installation instructions cover the basic rectangular design using 2' x 2' panels. There will be more complex designs that require a different or more complex grid layout.

### Step 1

Establish a vertical and horizontal control line with a laser or chalk line that is at the intersection of 4 panels.

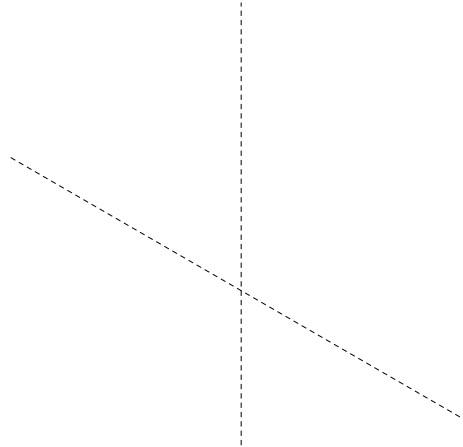

### Step 2

In order to assure proper horizontal alignment, it is recommended that a temporary ledger board be installed on the horizontal control line the entire length of the finished wall installation.

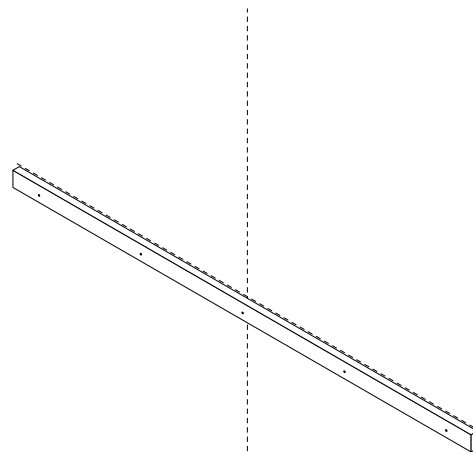

# Surface-Mounted System

## Installation

### Step 3

Begin the installation of the backer panels at the intersection of the vertical control line and the ledger board. Fasten to wall through the predrilled holes using appropriate anchor fasteners.

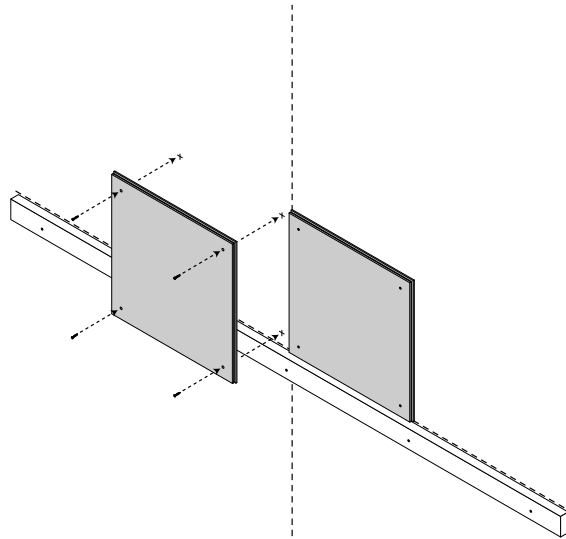

### Step 4

Each consecutive panel will contact the previous panel along the entire length of the vertical leg. With the contact area free of debris, continue the installation in both directions working from the control line out.

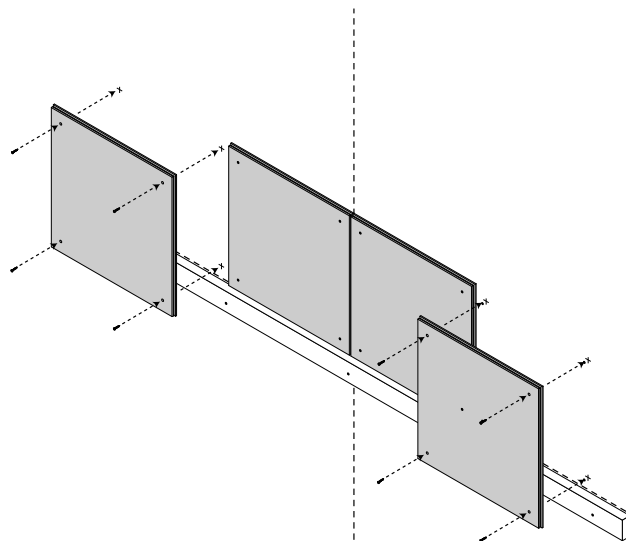

# Surface-Mounted System

## Installation

### Step 5

Using a straight edge on the vertical edge of the previously installed backer panel, align the second roll of backer panels with the first.

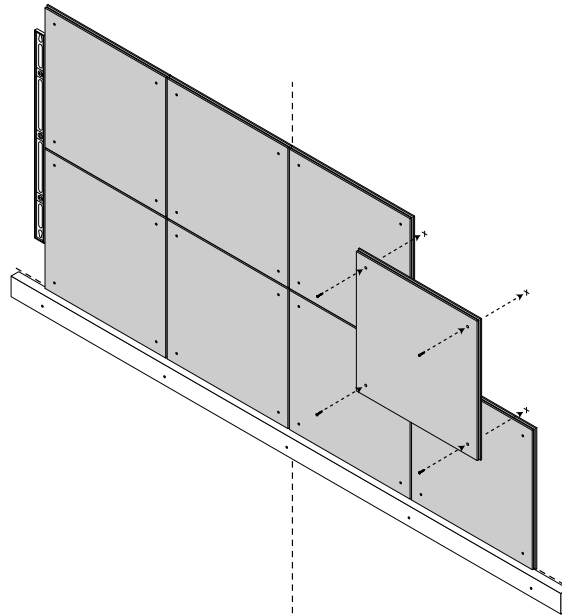

### Step 6

Once the upper panels are all installed, remove the ledge board and install the bottom row of panels aligning them vertically as described in the previous step.

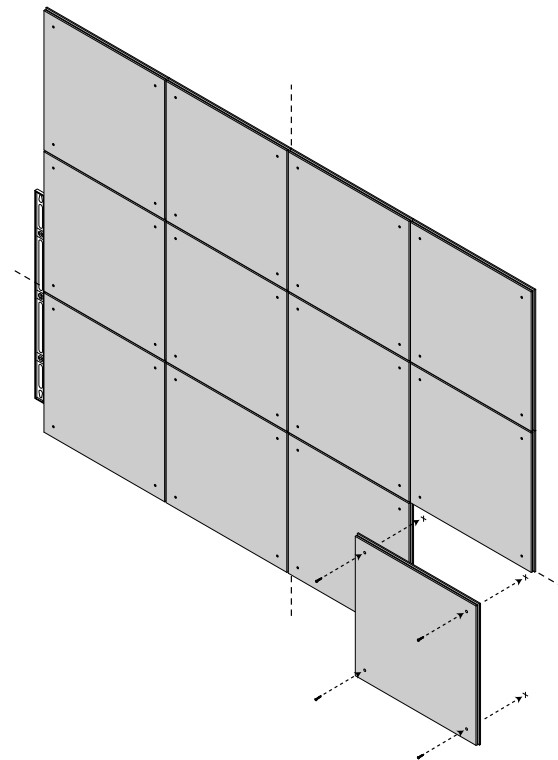



# Surface-Mounted System

## Installation

### Step 7

Install the pre-mitered friction-fit trim into the panel kerf on all four sides. Screws may be loosened on backer panel perimeter to fit bottom leg of trim behind panel. Once all the trim is in place, re-tighten the perimeter screws.

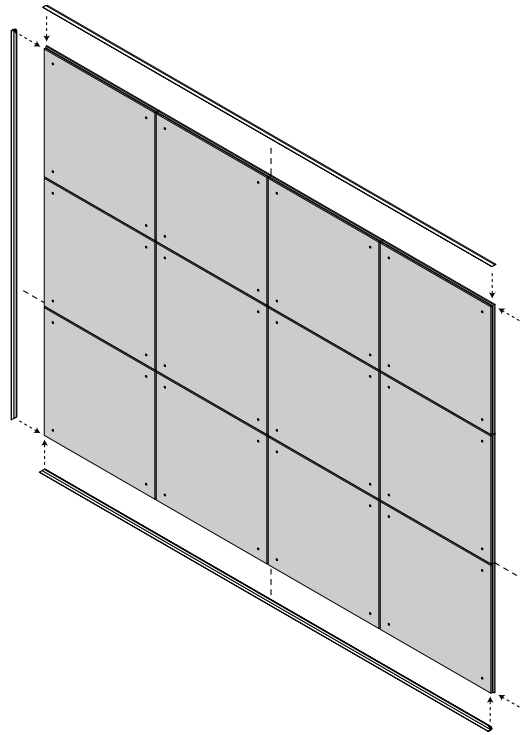

### Step 8

Gently pre-fit PIXELS panels in any order onto the backer panels. Using the heel of your hand, seat the PIXELS panel starting from top left uppermost corner to the right uppermost corner. Work down from both corners to the bottom until all edges are seated.

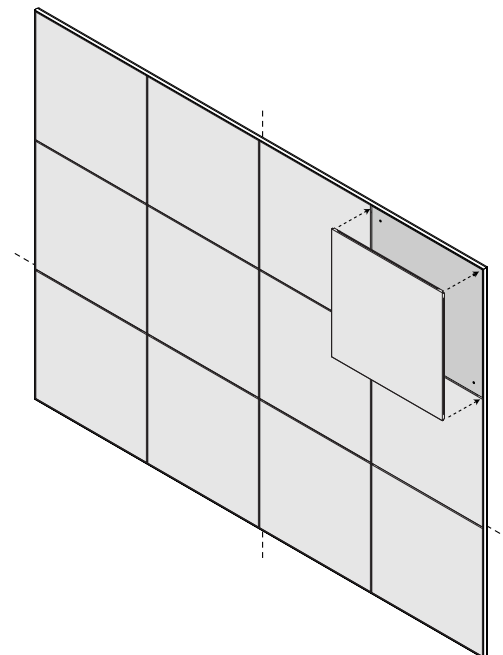
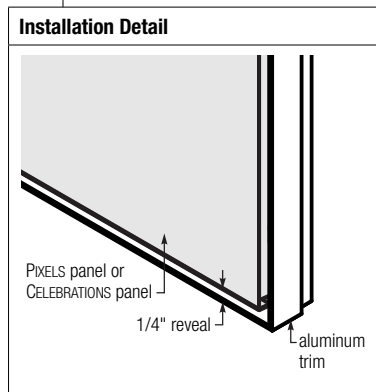

# Surface-Mounted System

## Installation

### Step 9

The finished system.

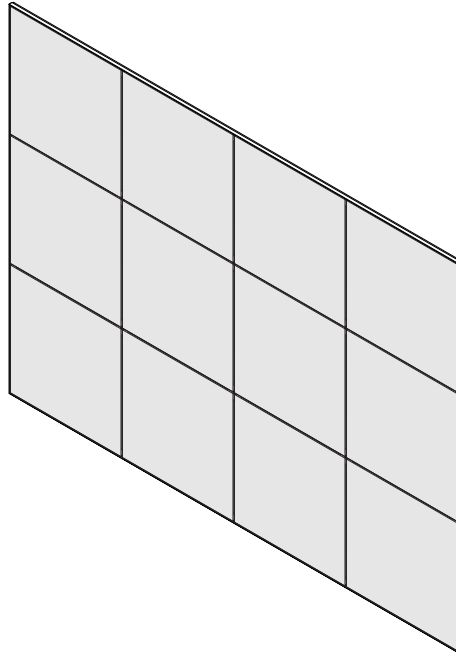

# Frame-Mounted Backlit System

## Components

In addition to the PIXELS CELEBRATION panels (see page 4), the following components are unique to the frame-mounted backlit system.

### Frame

#### Pre-Mitered Frame Segment

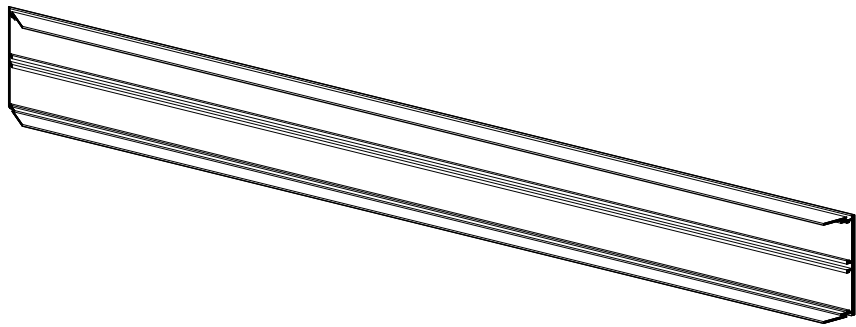

### Options

#### 4" Frame Profile

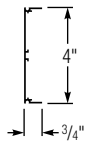

#### 6" Frame Profile

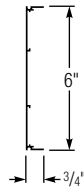

### Accessories

#### Elite Splice Plate

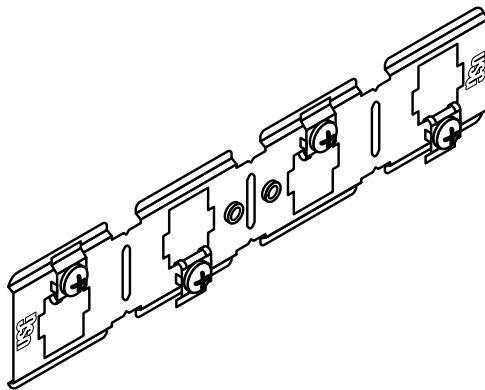

#### Perimeter Frame Attachment Clip (WMPFAC)

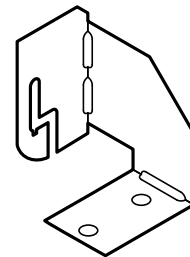

# Frame-Mounted Backlit System

## Components

### Grid

**FINELINE® DXF™ Main Tee, Pre-Cut**

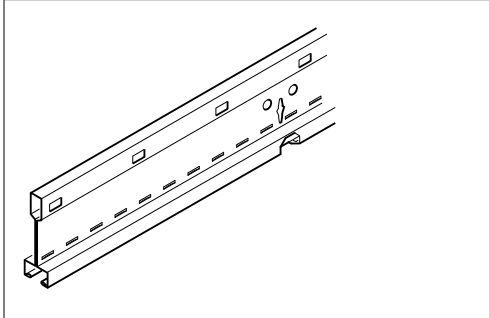

**FINELINE® DXF Cross Tee**

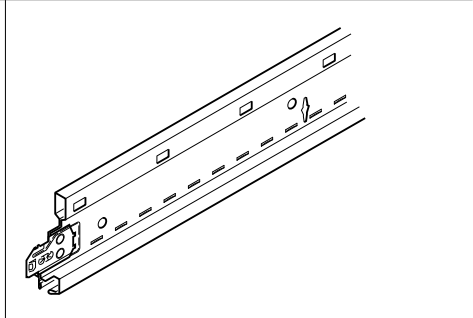

**Grid Attachment Clip (WMGAC)**

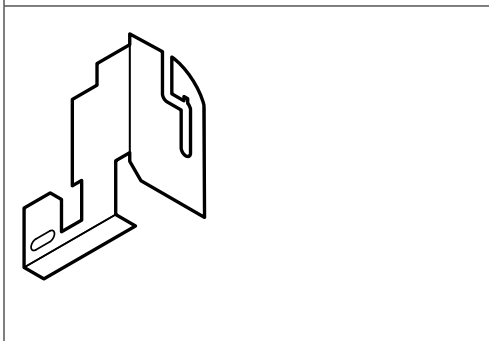

**Grid Support Bracket (WMGSB)**

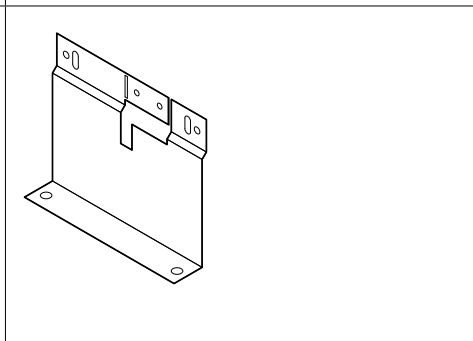

# Frame-Mounted Backlit System

---

## Components

---

### Backlit Option

#### Foam Gasket

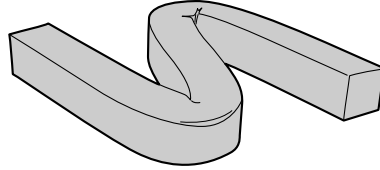

---

### Fasteners

#### Wall-Dog™ Fastener

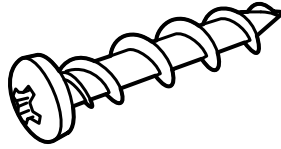

**Note:** Wall-Dog is a trademark of Powers Fasteners, Inc. For more information please visit [www.powers.com](http://www.powers.com)

# Frame-Mounted Backlit System

## Construction

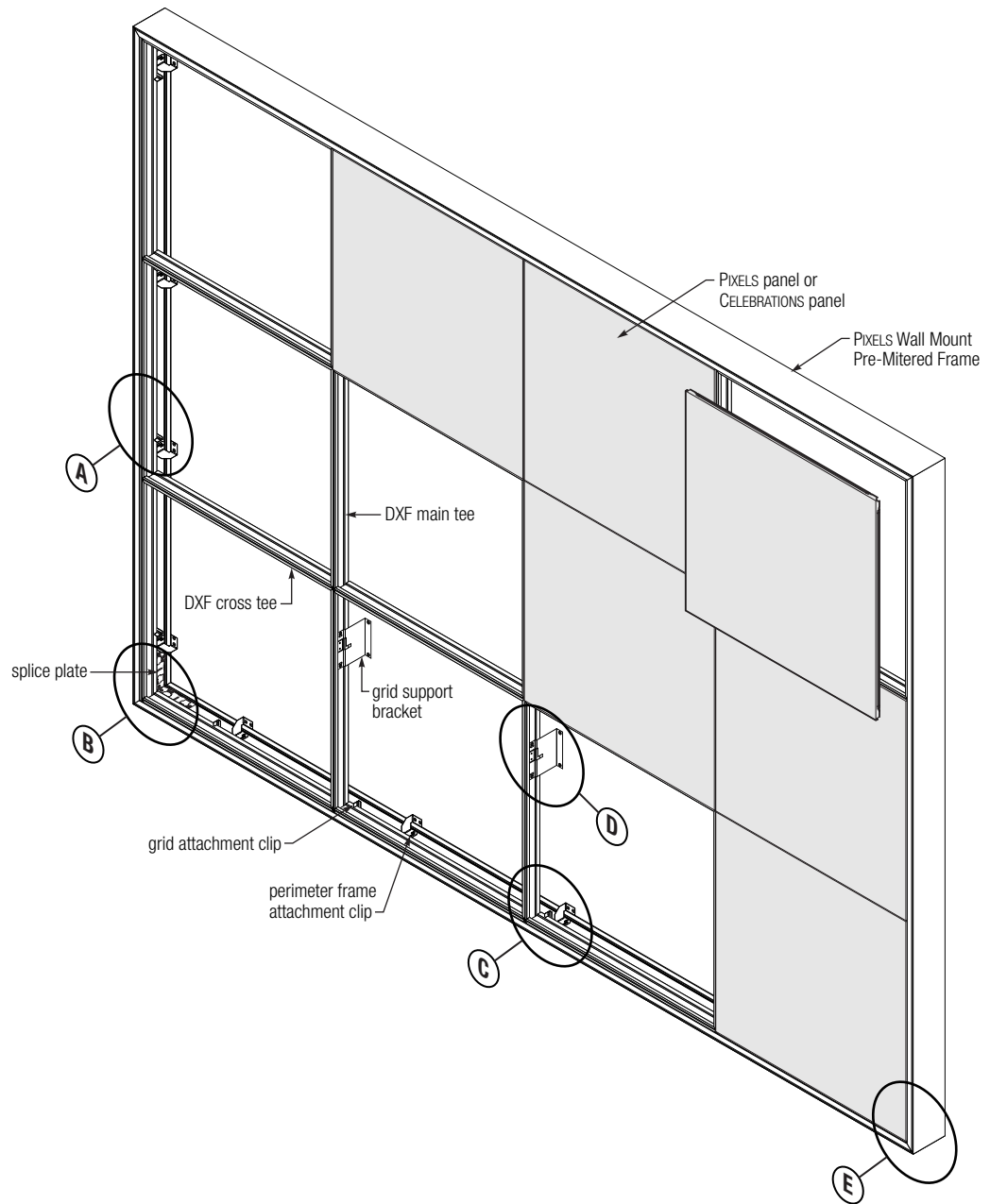

# Frame-Mounted Backlit System

## Construction

### Construction Details

#### A. Typical Perimeter Edge

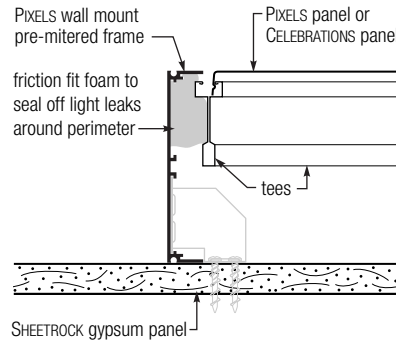

#### B. Corner Splice

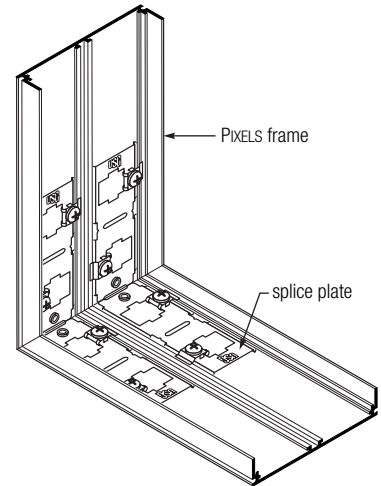

#### C. Perimeter Attachment Clips

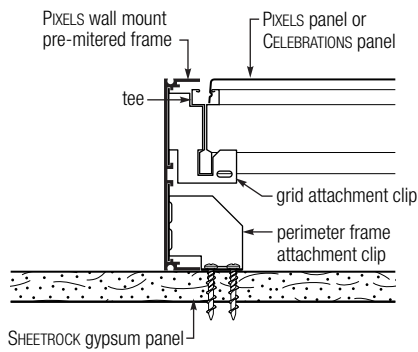

#### D. Grid Support Panel Intersection

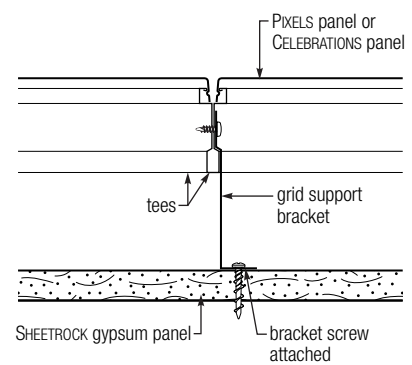

#### E. Corner

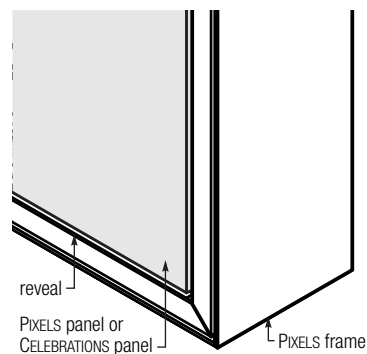

# Frame-Mounted Backlit System

## Installation – Perimeter Frame

**Note:** These installation instructions cover the basic rectangular design using 2' x 2' panels. There will be more complex designs that require a different or more complex grid layout.

### Step 1

Establish the bottom corner of the installation to be at least 8 inches off the floor and use a cross laser to determine both vertical and horizontal control lines.

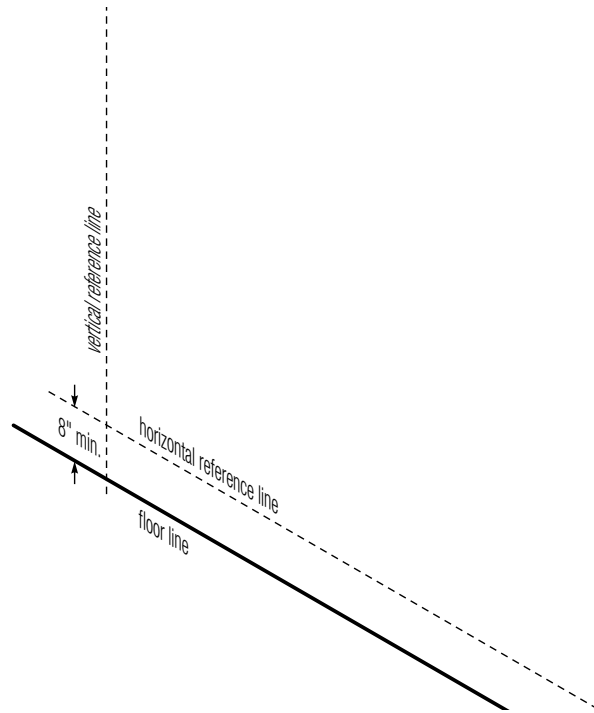

### Step 2

Install perimeter frame attachment clips (WMPFAC) inside of the trim per shop drawing supplied. Pre-assemble the corner splice into the bottom horizontal trim piece.

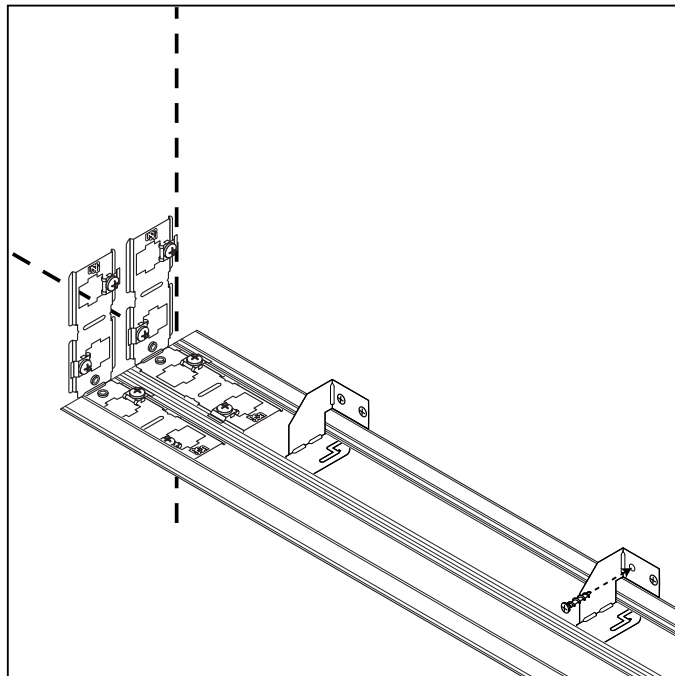
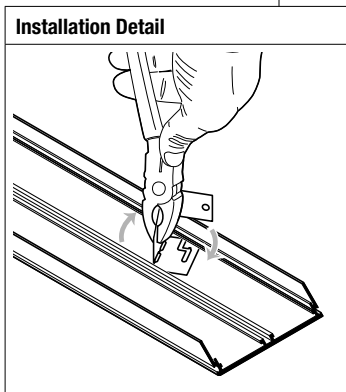



# Frame-Mounted Backlit System

## Installation – Perimeter Frame

### Step 3

Align lower edge of trim with reference control line and screw attach to wall using appropriate fasteners and anchors as necessary. (Wall-Dog™ fasteners work well)

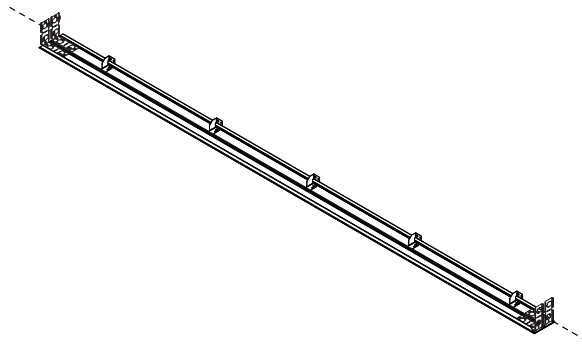

### Step 4

Install adjacent vertical trim into the corner splice and attach to wall aligning with vertical laser line.

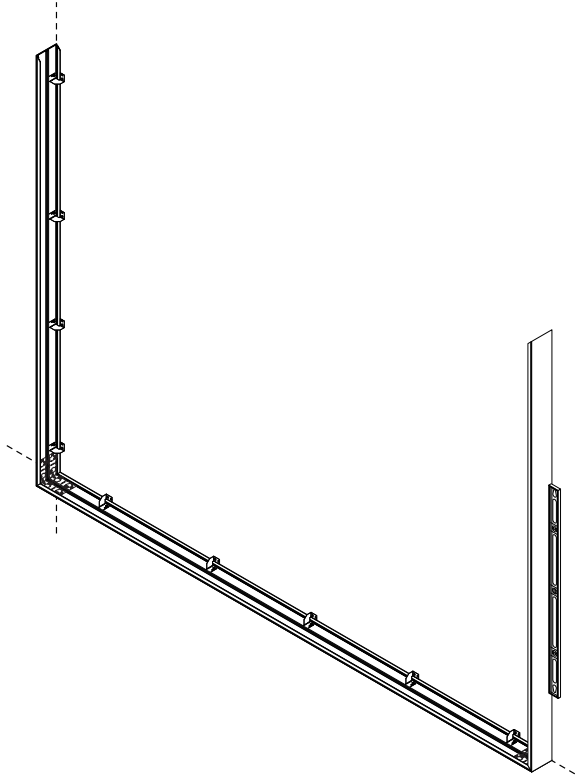

# Frame-Mounted Backlit System

## Installation – Perimeter Frame

### Step 5

Continue building perimeter trim frame per shop drawings. Verify that the frame is square by measuring diagonally corner to corner. If not square, adjust accordingly. FRAME MUST BE SQUARE!

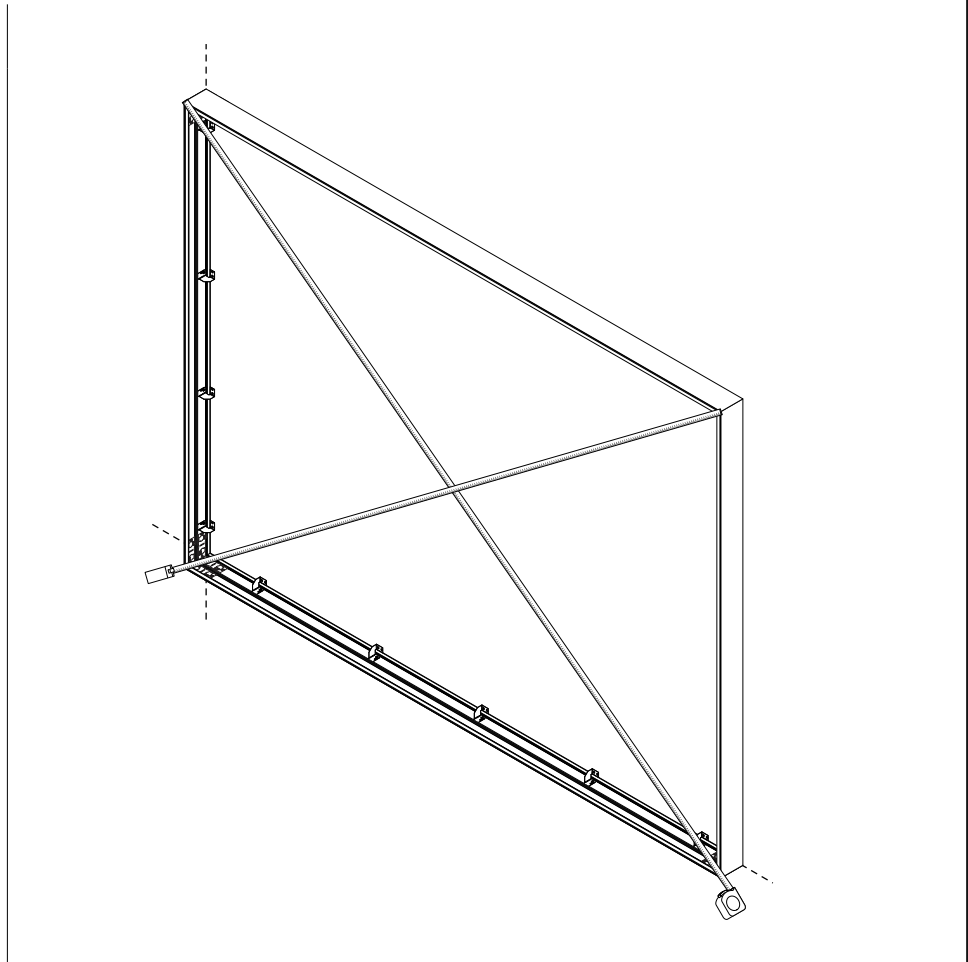

### Lighting

Once the perimeter trim frame is in place, lighting shall be installed per local codes and supplied shop drawings. The GE Tetra® PowerGrid system is an excellent choice for PIXELS backlit systems. See USG/GE Designed Together to Work Together program on page 32 for more information.



Designed Together to Work Together

# Frame-Mounted Backlit System

## Installation – Fineline® Grid

### Step 1

Install grid attachment clip (WMGAC) into perimeter trim per shop drawings supplied.

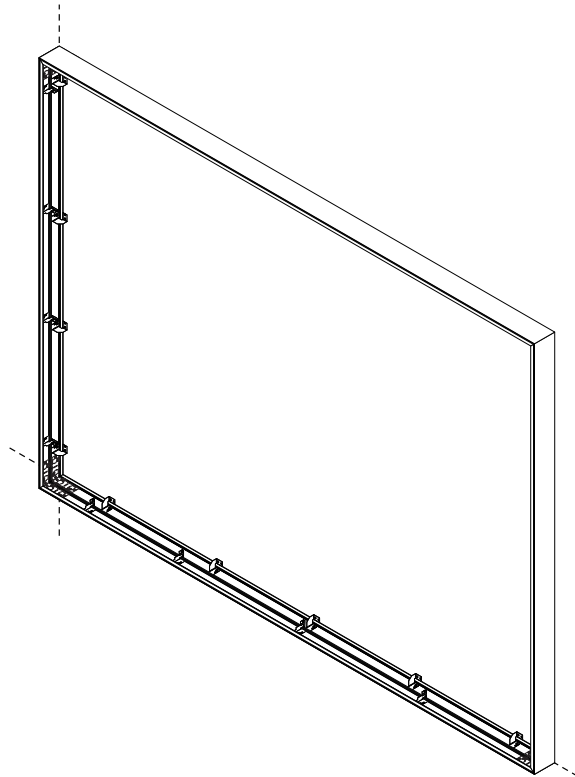

### Step 2

Beginning at the left side, attach main tee section to the grid attachment clip (WMGAC) and bend tabs to lock in place.

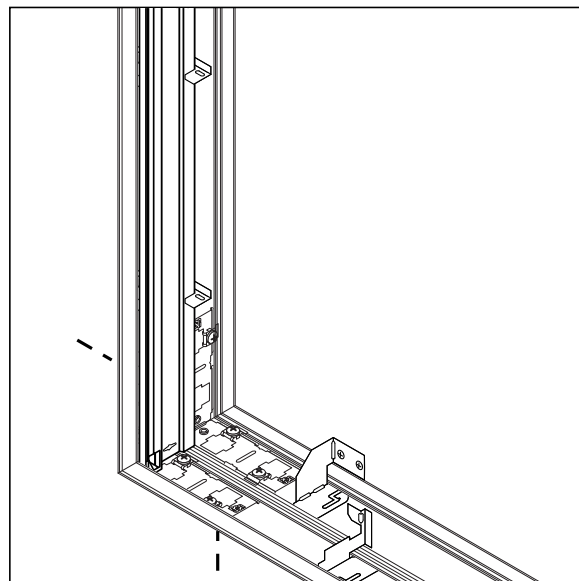
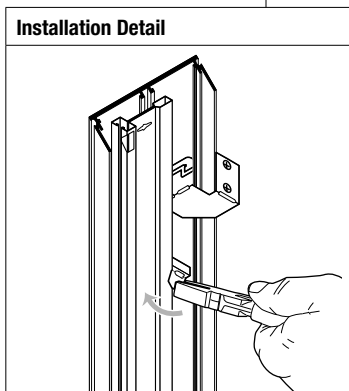

# Frame-Mounted Backlit System

## Installation – Fineline® Grid

### Step 3

Attach cross tees per the shop drawing and locate the next main tee section.

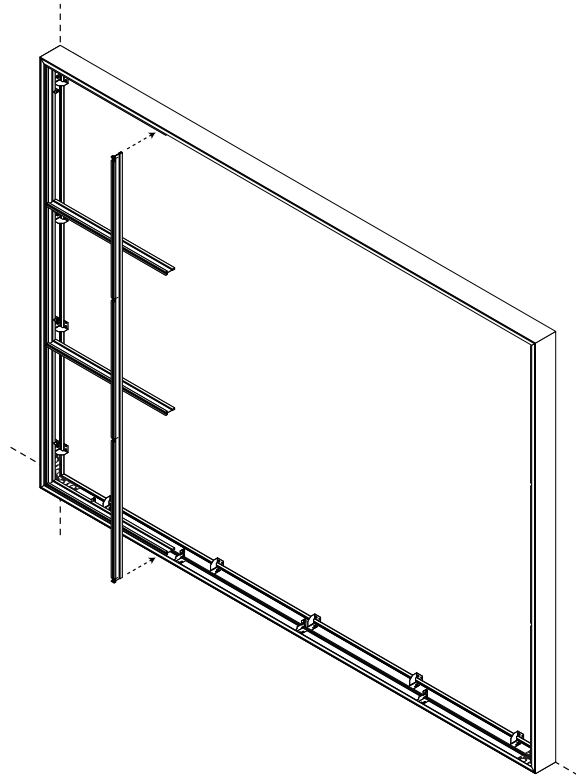

### Step 4

Attach cross tees to the top and bottom trim using WMGAC1.

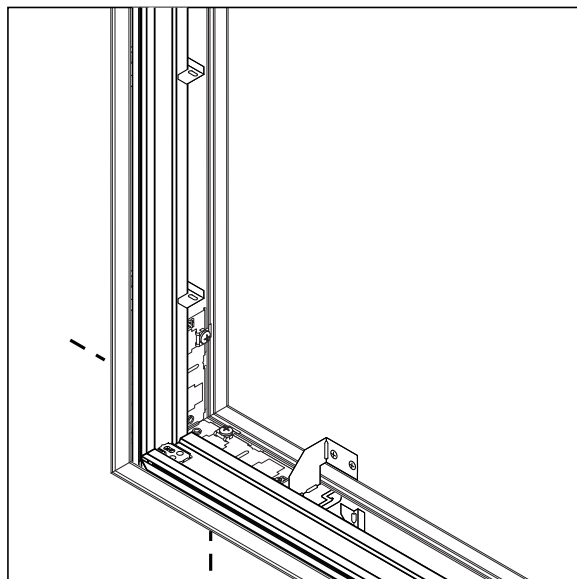
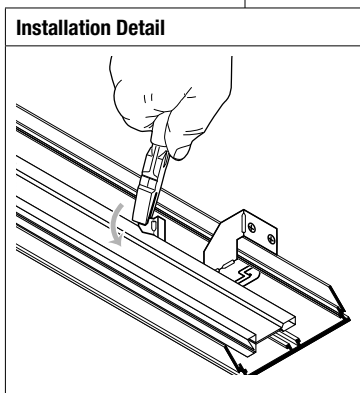

# Frame-Mounted Backlit System

## Installation – Fineline® Grid

### Step 5

Continue this procedure from left to right until reaching the trim on the right side.

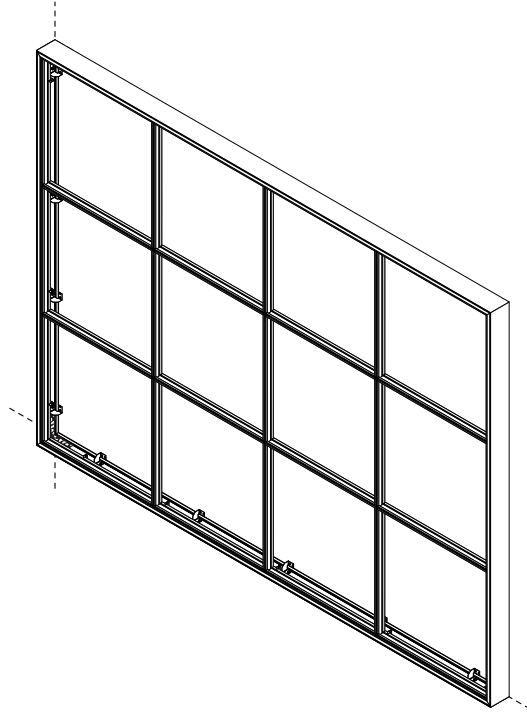

### Step 6

Install wall mount grid support brackets (WMGSB) on main tees per shop drawings.

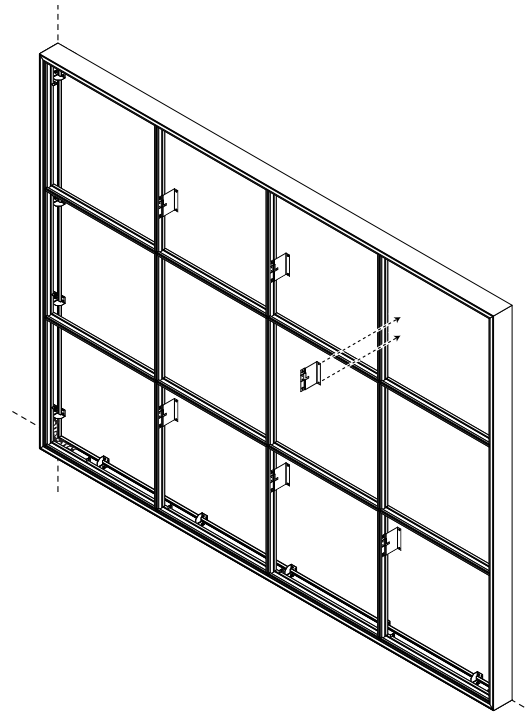

# Frame-Mounted Backlit System

## Installation – Fineline® Grid

### Step 7

Tuck foam into space between grid and trim to block light leaks. Be sure to push foam all the way to the face of the trim.

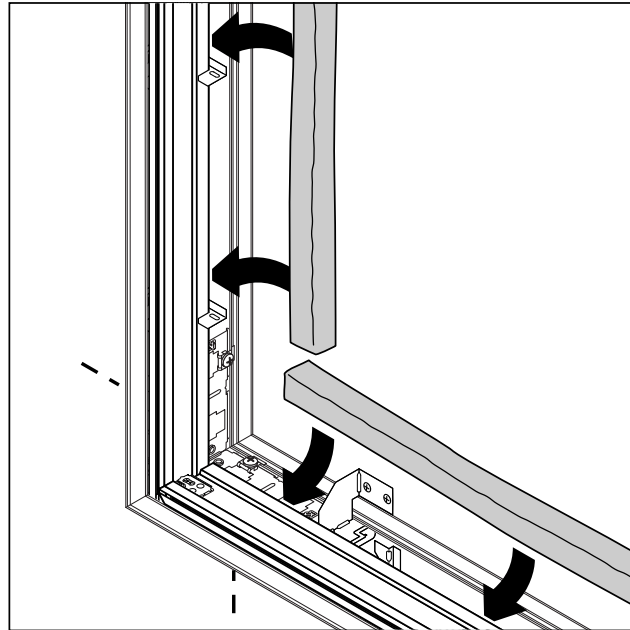
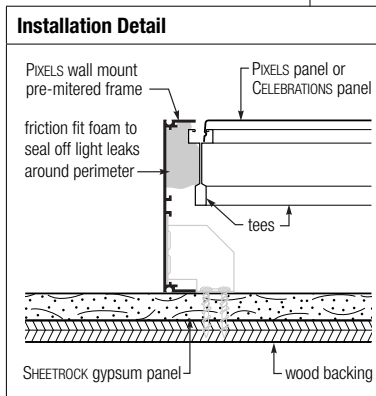

### Step 8

Assure the system is square.

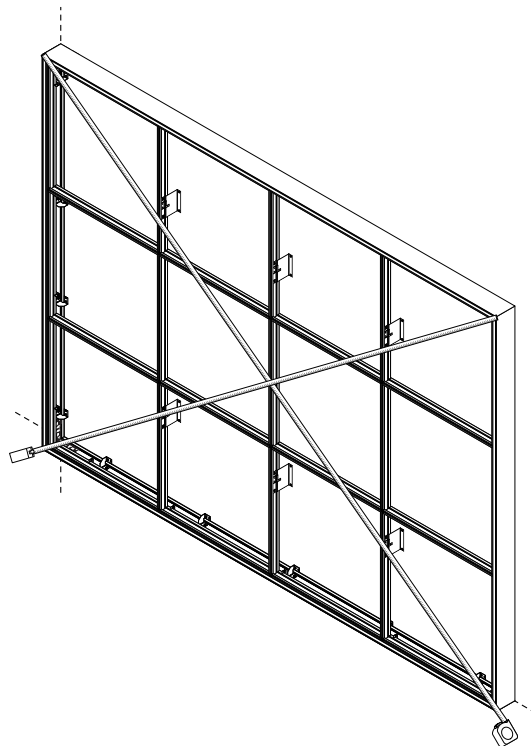

# Frame-Mounted Backlit System

## Installation – Pixels Panels

### Step 9

Install CELEBRATION or PIXEL panels per shop drawings.

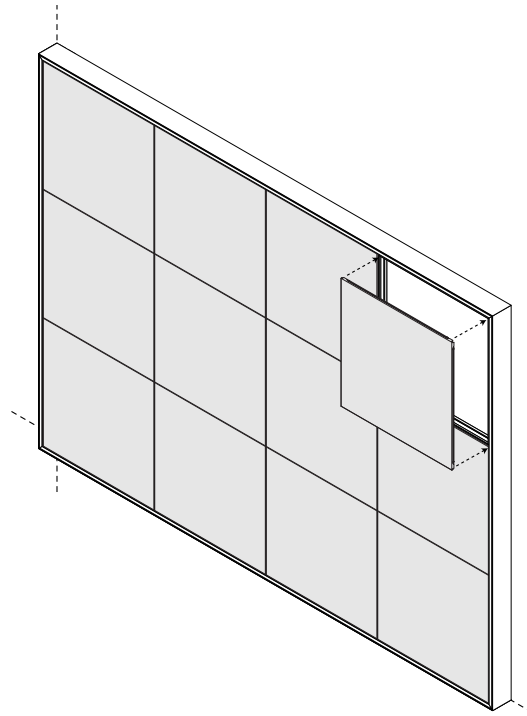
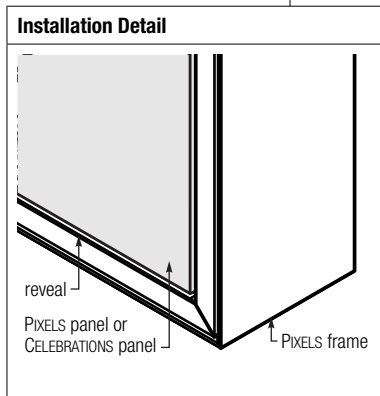

### Step 10

The finished system.

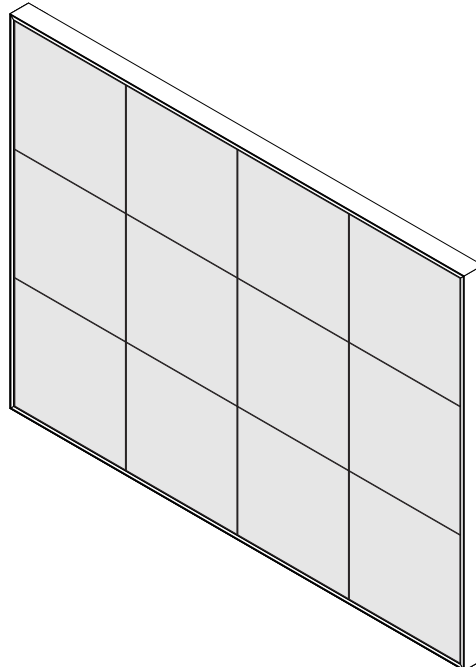

# Appendix

## Sample Shop Drawings

### Bill of Materials

BILL OF MATERIAL - 4" TRIM					w.o. 81433	
PART NO	DESCRIPTION	FINISH	QTY	OVG	TOTAL	
1	109.68" straight w/ dbl 45° miter	silver satin	2		2	
2	37.68" straight w/ dbl 45° miter	"	2		2	
67832	Celebration trim clip	mill	8	1	9	
67830	splice plate	"	8	1	9	

BILL OF MATERIAL - Fineline Grid					
PART NO	DESCRIPTION	FINISH	QTY	OVG	TOTAL
MT1	36.56" Fineline main tee cut to match	wht/blk	4	1	5
CT1	36.00" Fineline cross tee	"	6	1	3
218659	Pixels wall mount clips	galv.	14	0	14

BILL OF MATERIAL - Celebration Pixel Panels					
PART NO	DESCRIPTION	FINISH	QTY	OVG	TOTAL
P1 - P3	36" x 36" Celebration Pixels Panel	silver satin	3	0	3

4" Compasso Elite		
straight	curve	corners
25	0	0

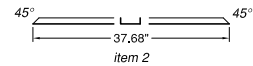
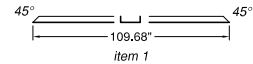

**PIXELS™**

silver satin face paint  
DXF grid w/ Celebration

GE - Nela Park

USG Building Systems Ceilings Solutions Group 1000 Crocker Road Westlake, Ohio 44145-1089 tel 440 892 7363 fax 440 892 7173	ORDER NO.	238903
	DRWN BY	S.M.P.
	DATE	8-16-12
	CKD. BY	
SHEET		1 OF 4

### Grid and Panels

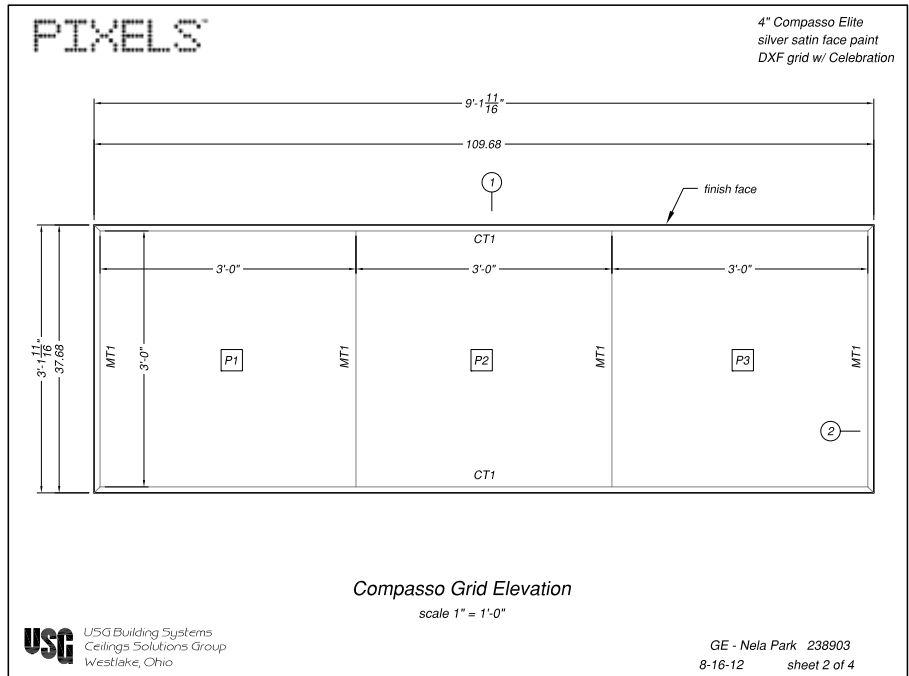



# Appendix

## Sample Shop Drawings

### Lighting

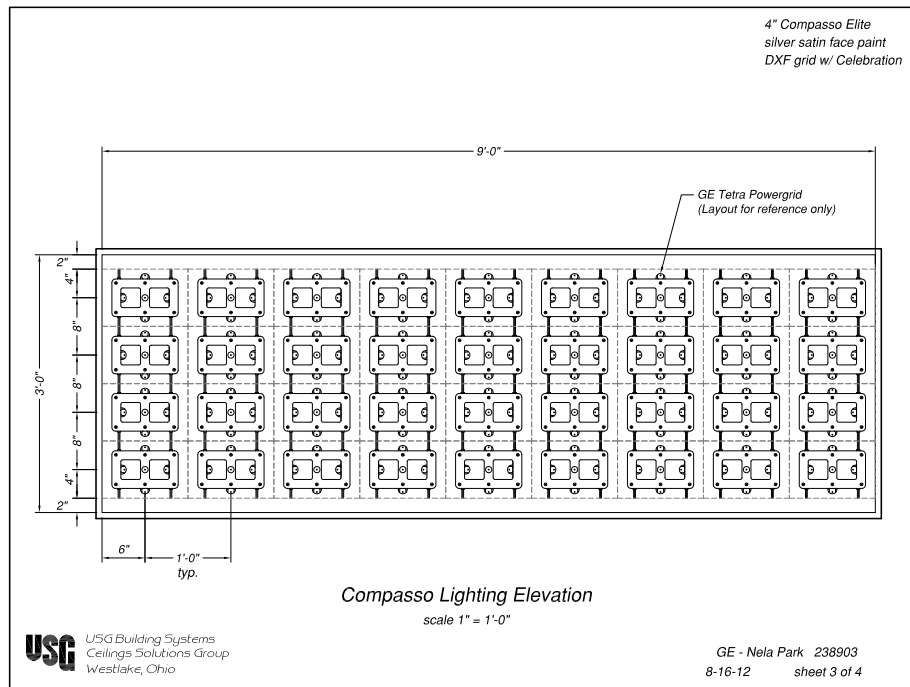

### View From Front

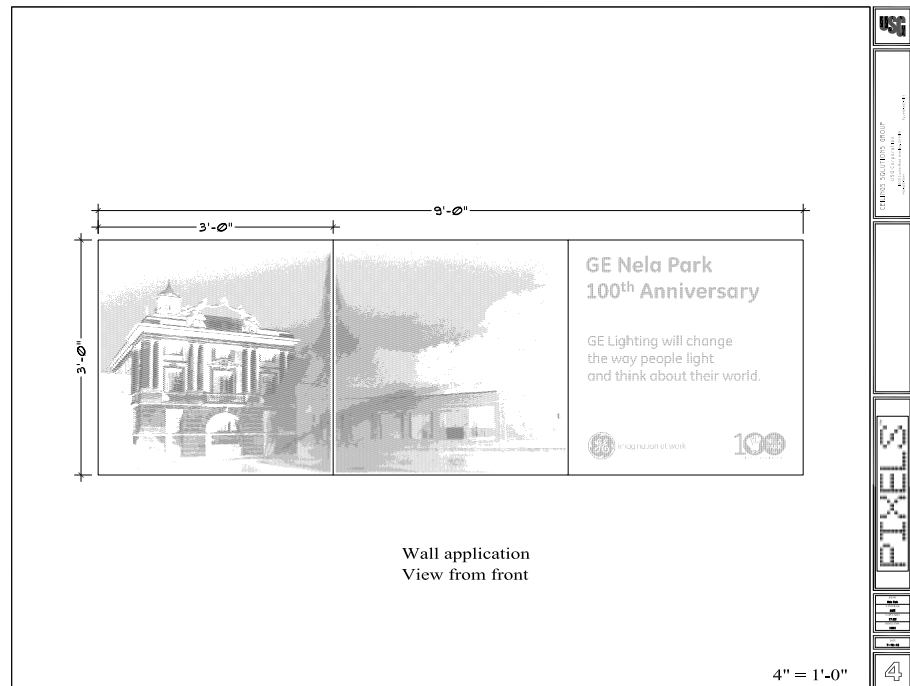

# Appendix

USG | GE

Designed Together to Work Together

## USG Pixels™ Wall-Mounted Systems with GE Tetra® PowerGrid



Designed Together to Work Together

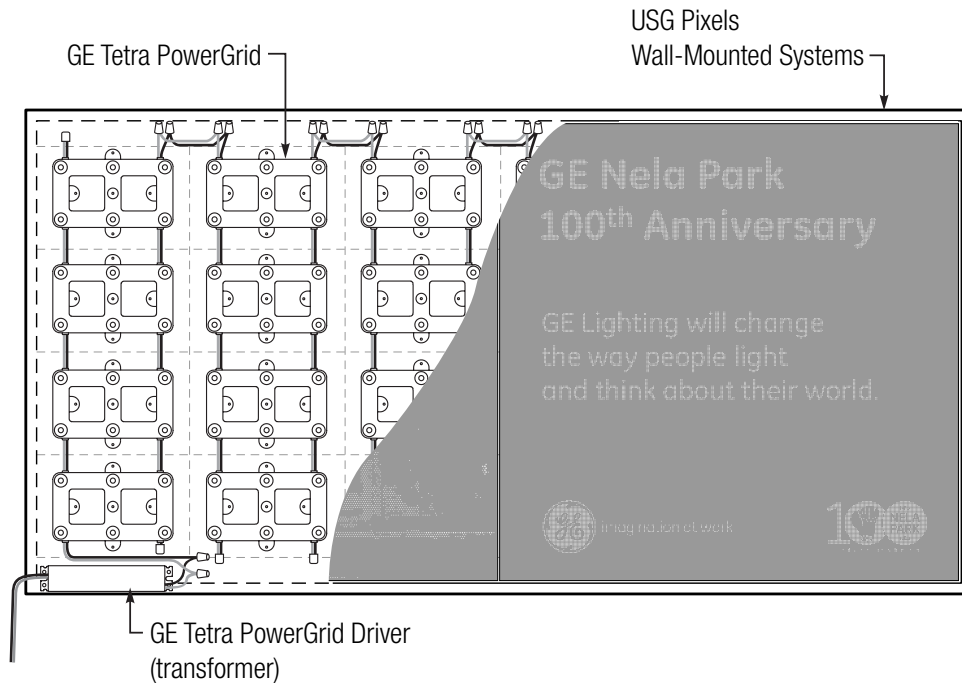

**GE Tetra PowerGrid**  
[www.gelightingsolutions.com](http://www.gelightingsolutions.com)  
1-888-694-3533

**USG Pixels Wall-Mounted Systems**  
[www.usg.com](http://www.usg.com)  
1-800-950-3839



**Prouct Literature**

Data sheet: IC605  
Design guide: IC566  
Check sheet: IC607

**Notice**

We shall not be liable for incidental and consequential damages, directly or indirectly sustained, nor for any loss caused by application of these goods not in accordance with current printed instructions or for other than the intended use. Our liability is expressly limited to replacement of defective goods. Any claim shall be deemed waived unless made in writing to us within thirty (30) days from date it was or reasonably should have been discovered.

**Trademarks**

The following are trademarks of USG Interiors, LLC, or a related company: PIXELS, CELEBRATION, DXF, FINELINE, USG, USG in stylized letters. GE Lighting Solutions, LLC is a subsidiary of the General Electric Company. The GE brand logo, Tetra are trademarks of the General Electric Company. © 2012 GE Lighting Solutions, LLC. Wall-Dog is a trademark of Powers Fasteners, Inc.

**Safety First!**

Follow good safety/industrial hygiene practices during installation. Wear appropriate personal protective equipment. Read MSDS and literature before specification and installation.



Manufactured by  
USG Interiors, LLC  
550 West Adams Street  
Chicago, IL 60661

usg.com  
seismicceilings.com  
sustainableceilings.com  
usgdesignstudio.com

IC606/12-12  
© 2012, USG Interiors, LLC  
Printed in U.S.A.